



# City of Columbia

701 East Broadway, Columbia, Missouri 65201

Department Source: Community Development - BSD

To: City Council

From: City Manager & Staff

Council Meeting Date: April 18, 2016

Re: Adoption of the 2015 International Code Council Family of Codes, with Amendments

## Executive Summary

The Building Construction Codes Commission (BCCC) has completed its review of the 2015 International Code Council family of codes and the 2014 National Electrical Code for adoption by the City. While the majority of the code changes in this cycle consist of clarifications and reformatting, there are several major code changes including required storm shelters for educational (K through 12 schools) and critical emergency operations use groups (911 call stations, fire, rescue, ambulance, and police stations), as well as new commercial and residential energy efficiency requirements. The Environment and Energy Commission (EEC) also has provided recommendations on the energy efficiency requirements in the International Residential Code (IRC) and the International Building Code (IBC).

## Discussion

The Building Construction Codes Commission is authorized by Chapter 6 of the City Code to "review the Building and other codes periodically for updating and recommending changes." After obtaining authorization to review the 2015 codes from the City Council in March 2015, the BCCC and its committees met frequently from May 2015 to January 2016, evaluating the effect of the new codes and recommending local amendments. BCCC members, representatives of the Building and Site Development Division of the Community Development Department, the Fire Department, and the Inspections Division of Boone County Resource Management attended the meetings.

The Environment and Energy Commission (EEC), following its charge in Chapter 2 of the City Code to "Act in an advisory capacity to the council in all matters pertaining to environmental protection, which could include questions of energy efficiency and conservation, and of changing technology," has reviewed the BCCC recommendations. The EEC has provided several recommended amendments to the energy efficiency requirements for single and two family construction and commercial structures, including multiple-family and institutional residential structures. A summary of the EEC recommendations is provided at the end of this discussion and in the attachments.

Below is a list of selected major code changes and other proposed amendments. All amendments appear in bold font/strikethrough in the attached proposed ordinances.



## Significant Code Changes

1. **Storm shelters.** The most significant change of this code cycle is the new storm shelter requirement (ICC 500) in the 2015 International Building Code (IBC). Because Central Missouri is in an area where the design wind speed for tornadoes is 250 mph [See attached Figure 304.2(1)] the 2015 IBC section 423 requires storm shelters to be constructed in accordance with ICC 500 for the following use groups;

**423.3 Critical emergency operations.** 911 call stations, emergency operations centers and fire, rescue, ambulance and police stations.

Exception: Buildings meeting the requirements for shelter design in ICC 500.

**423.4 Group E occupancies.** All group E occupancies with an occ. load of 50 or more.

Exceptions:

1. Group E daycare facilities.
2. Group E occupancies accessory to places of religious worship.
3. Buildings meeting the requirements for shelter design in ICC 500.

None of the existing buildings in the City would meet the requirements for shelter design in ICC 500 if they were built today.

The 2015 IBC is not clear how building additions may trigger the requirement for a storm shelter. According to an ICC representative, the authority having jurisdiction would determine the requirement for constructing a storm shelter for an addition on a case by case basis. An administrative policy would likely need to be established to clarify the issue.

There will be many additional structural, engineering, and procedural requirements for shelters designed in compliance with ICC 500. Because of the additional expense related to these requirements, the BCCC members want to make sure all stakeholders are aware of this major code change. The BCCC proposes no amendments to these new provisions.

2. **Energy efficiency.** As in the last code cycle the BCCC reviewed new energy code requirements and considered both the benefits of the new requirements and the associated expenses. The BCCC recommends adopting the 2015 Energy Code requirements with the following amendments.

### **Commercial**

- a. The 2015 International Energy Efficiency Code **Section C408** requires **System Commissioning**. All members agreed system commissioning, adjusting, and balancing is advisable. It is the opinion of the committee that the additional required plans and documentation are both cumbersome, time consuming, and expensive. Consensus was that system balancing, performance, and control can be achieved without these additional burdens and suggest the following amendments.



## **C408.2 Mechanical systems and service hot water heating systems commissioning and completion requirements. Amend as follows;**

Prior to the final mechanical and plumbing inspections, the registered design professional or approved agency ~~shall~~ **should** provide evidence of mechanical system commissioning and completion in accordance with the provisions of this section.

### **C408.3.1 Functional testing. Amend as follows.**

Prior to passing final inspection, the registered design professional ~~shall~~ **should** provide evidence that the lighting control systems have been tested to ensure that control hardware and software are calibrated, adjusted, programmed and in proper working condition in accordance with the construction documents and manufacturer's instructions.

- b. As in the last code cycle the BCCC voted to keep the amendment to IBC 1301.1.2 for R-2, R-3, and R-4 use groups (attached). This amendment prescribes insulation values, thermal envelope sealing, and thermal transmittance values for windows.

## **Residential One and Two Family**

- a. **N1101.3 Scope.** Add the attached figure labeled 2015 Residential Energy Code Requirements and make it a prescriptive means of code compliance. The committee believes building to this diagram both meets the intent of the code and simplifies the requirements for builders and inspection staff. Consensus was that simplification would translate to more consistent compliance, energy efficiency and affordability.
- b. **N1102.2.9 Basement walls. Amend first sentence as follows;** Walls associated with ~~conditioned~~ **finished** basements shall be insulated from the top of the basement wall down...  
This is applicable only to the foundation wall portions of unfinished basements. To insulate these walls before it is determined what the use will be and where plumbing, mechanical, and electrical components will be located leads to excess cost and duplication of work. This amendment is in line with the goal of affordability.
- c. **N1102.4.1.2 Testing. Amend as follows (Amended portion in bold font);** The building or dwelling unit shall be blower door tested **as deemed necessary by the building official** and verified as having an air leakage rate...Because dwellings never fail the blower door test when constructed per the prescriptive code requirements the blower door test is unnecessary. When, through un-craftsman-like work, compliance with prescriptive code requirements is questionable, the blower door test may be



required. Because blower door testing is several hundred dollars this amendment is in line with the goal of affordability.

- d. **N1102.4.4 Rooms containing fuel burning appliances. Delete.** This section requires rooms “where open combustion air ducts provide combustion air to open combustion fuel-burning appliances” (Typically 80% efficiency gas furnaces and water heaters) to be isolated from the building thermal envelope by means of insulation and fully gasketed doors. The committee believes this requirement, in conjunction with the requirement to bring combustion air into the room, may cause unintended negative consequences such as **freezing** of water pipes or builders using less efficient electric equipment. The committee also believes isolating this room from the thermal envelope entails unnecessary expense.
- e. **Appendix U (Appendix RB in the International Energy Conservation Code) Solar Ready Provisions.** This appendix is not mandatory unless adopted by the adopting ordinance. The BCCC believes the provisions of this appendix will only add unnecessary construction documentation requirements and does not propose adoption of this appendix.

3. **Accessibility.** The BCCC is proposing two accessibility amendments to IBC chapter 11 as follows;

**1104.4 Multistory buildings and facilities. Amend exception 1 as follows (Amended portion in bold font);**

**Exceptions:**

1. An accessible route is not required **in private buildings or facilities that are less than three stories or** to stories and mezzanines that have an aggregate area of not more than 3,000 square feet and are located above and below accessible levels. This exception shall not apply to:
  - 1.1 Multiple tenant facilities of group M occupancies containing five or more tenant spaces used for sales and rental of goods and where at least one such tenant space is located on a floor level above or below the accessible levels;
  - 1.2 Stories or mezzanines containing offices of health care providers (Group B or I);
  - 1.3 Passenger transportation facilities and airports (Group A-3 or B) or;
  - 1.4 Government Buildings.

This language intends to conform with the ADA which states;

**Exceptions:**

1. In private buildings or facilities that are less than three stories or that have less than 3000 square feet per story, an accessible route shall not be required to connect



stories provided that the building or facility is not a shopping center, a shopping mall, the professional office of a health care provider, a terminal, depot or other station used for specified public transportation, an airport passenger terminal, or other type of facility as determined by the Attorney General.

**1109.5.1 Minimum number (Drinking fountains). Amend as follows;** ~~No fewer than two drinking fountains shall be provided. One drinking fountain shall comply with the requirements for people who use a wheelchair and one drinking fountain shall comply with the requirements for standing persons.~~

As the code is written a minimum of two drinking fountains is always required because the maximum height for wheelchair accessibility is 34" and the minimum for standing persons is 36" the BCCC. The BCCC voted that if the plumbing code only required one drinking fountain it could meet the standard for wheelchair accessibility. The intent was to limit cost. Note: **Staff has some concerns regarding this amendment; a member of Great Plains ADA Center has stated the proposed amendment is in direct conflict with ADA requirements.**

4. **Existing structures.** Chapter 34 **Existing Structures** has been removed from the IBC. The provisions of this chapter are now contained in the International Existing Building Code (IEBC). IBC section 101.4.7 states, "The provisions of the International Existing Building Code shall apply to matters governing the repair, alteration, change of occupancy, addition, to and relocation of existing buildings." The IEBC goes into much greater detail and clarification than Chapter 34 provided without changing the intent of the provisions.
5. Also of note are;
  - A. The BCCC recommendation to adopt appendices R and S in the 2015 International Residential Code. These appendices establish requirements for "Light Straw-Clay Construction" and "Strawbale Construction".
  - B. The BCCC recommendation to add a commission member "Experienced in Energy Conservation". (IBC amendment section 113.1.2)

## **EEC Recommendations**

The Environment and Energy Commission has made a number of recommendations regarding energy efficiency that differ from the BCCC recommendations, which are summarized below and in the attachments to this report.

The EEC recommendations would make the following changes to the draft ordinance:



# City of Columbia

701 East Broadway, Columbia, Missouri 65201

1. Revise the proposed 2015 Residential Energy Code Requirements diagram to require mandatory air leakage testing, state a target air leakage rate, and require blower door and duct pressure tests; require termite barriers.
2. Revise Table 301.2(1) to rate Missouri as “moderate to heavy” termite risk rather than “very heavy” risk as recommended by the BCCC (moderate to heavy is the rating given to Missouri in the published code);
3. Amend the International Residential Code N1102.4.1.2 to require blower door (air leakage) testing (currently it is not recommended a requirement by BCCC);
4. Amend IBC 1301.1.2 to change required insulation values for use groups R-2, R-3, and R-4 (housing other than 1 or 2 family) from R38 to R49 for ceiling or roof and R15 to R20 for exterior walls; require slab insulation rated R10 and require a termite barrier in accordance with R318.3j; and change window “U” value (thermal transmittance rating) from 0.55 to 0.40.
5. Adopt Appendix U, Solar Ready Provisions, as part of the International Residential Code.

## Fiscal Impact

Short-Term Impact: None

Long-Term Impact: None

## Vision & Strategic Plan Impact

### [Vision Impacts:](#)

Primary Impact: Environment, Secondary Impact: Health, Social Services & Affordable Housing, Tertiary Impact: Not Applicable

### [Strategic Plan Impacts:](#)

Primary Impact: Not Applicable, Secondary Impact: Not Applicable, Tertiary Impact: Not Applicable

### [Comprehensive Plan Impacts:](#)

Primary Impact: Livable & Sustainable Communities, Secondary Impact: Not applicable, Tertiary Impact: Not Applicable



# City of Columbia

701 East Broadway, Columbia, Missouri 65201

## Legislative History

Date	Action
03/02/15	REP33-15 Council authorized the Building Construction Codes Commission to review the 2015 International Codes.
07/20/15	R 120-15 Council directed the City Clerk to place on file for a period of ninety days the 2015 International code Council family of codes and the 2014 National Electric Code.

## Suggested Council Action

Adopt the 2015 International Code Council family of Codes (International Residential Code, International Building Code, International Energy Conservation Code, International Existing Buildings Code, International Plumbing, Mechanical, and Fuel Gas Codes, International Fire Code) and the 2014 National Electric Code to be in full force and effect on October 1, 2016.

Introduced by \_\_\_\_\_

First Reading \_\_\_\_\_

Second Reading \_\_\_\_\_

Ordinance No. \_\_\_\_\_

Council Bill No. B 107-16

**AN ORDINANCE**

repealing Article VI of Chapter 6 of the City Code relating to the 2012 Edition of the International Residential Code for One- and Two-Family Dwellings and enacting in lieu thereof a new Article VI adopting the 2015 Edition of the International Residential Code for One- and Two-Family Dwellings; and fixing the time when this ordinance shall become effective.

BE IT ORDAINED BY THE COUNCIL OF THE CITY OF COLUMBIA, MISSOURI, AS FOLLOWS:

SECTION 1. Article VI of Chapter 6 of the Code of Ordinances, City of Columbia, Missouri, relating to the 2012 Edition of the International Residential Code for One- and Two-Family Dwellings, is hereby repealed and in lieu thereof a new Article VI, relating to the 2015 Edition of the International Residential Code for One- and Two-Family Dwellings, is hereby enacted reading in words and figures as follows:

CHAPTER 6. BUILDINGS AND BUILDING REGULATIONS

...

ARTICLE VI. ONE- AND TWO-FAMILY DWELLING CODE

Sec. 6-65. Adopted.

The 2015 Edition of the International Residential Code for One- and Two-Family Dwellings, published by the International Code Council, Inc., including Appendices A, B, C, E, F, G, H, K, N, R and S, one copy of which has been on file with the city clerk for a period of ninety (90) days prior to the adoption of this article, is hereby adopted by reference and made a part of the Code of Ordinances, City of Columbia, Missouri as fully as if set forth in its entirety. At least one (1) copy of the 2015 Edition of the International Residential Code for One- and Two-Family Dwellings shall remain on file in the office of the city clerk and shall be kept available for public use, inspection and examination.

Sec. 6-66. Amendments.

The code adopted by this article is hereby amended by substituting the following sections in lieu of those sections with corresponding numbers in the code, or, where there



is no corresponding section in the code, the following sections shall be enacted as additions to the code:

*R101.1 Title.* These provisions shall be known as the Residential Code for One- and Two-Family Dwellings of the City of Columbia, and shall be cited as such and will be referred to herein as “this code.”

*R102.5.1* Appendices A, B, C, E, F, G, H, K, N, R and S are hereby adopted as published.

*R103.1 Creation of enforcement agency.* Delete in its entirety.

*R103.2 General.* The building official is hereby authorized and directed to administer and enforce all provisions of this code. The building official shall be the director of community development.

*R104.10.1 Flood Hazard Areas.* Delete in its entirety.

*R105.1 Permits required.* Add to paragraph: All building, electrical, plumbing, mechanical and fuel gas permits may be issued to the general contractor, on behalf of master electrical, master mechanical, and master plumbing contractors, for new one- and two-family dwellings and building alteration or building additions to one- and two-family dwellings. All electrical, mechanical, plumbing and fuel gas work must be performed by trade contractors licensed by the City of Columbia for the appropriate trade or as allowed by ordinance.

Vacant lot areas left from demolition shall be filled, leveled and graded to prevent ponding. The lot shall be left in a natural buildable condition without hazards and mowable. There shall be sufficient vegetative cover to prevent erosion. The complete structure shall be removed and all accessory structures are to be removed at the time of demolition of the primary structure.

*R105.2, No. 2.* Fences not over twelve (12) feet high.

*R106.2 Site plan or plat plan.* Add paragraph: More than two (2) single family dwellings, multiple duplexes, and/or townhomes on one (1) lot shall require commercial civil/site documents per IBC 107.2.5 (including Columbia Code of Ordinances amendment), sealed by a professional engineer licensed in the State of Missouri.

*R109.1.6.1 Elevation Documentation.* Delete.

*R112.1 General.* Any aggrieved person shall have the right to appeal a decision of the code official to the building construction codes commission. Applications for appeal shall be filed in accordance with the procedures set out in Section 113 of the Building Code of Columbia, Missouri.

*R112.2.1 Determination of substantial improvements in areas prone to flood.* Delete in its entirety.

*R112.2.2 Criteria for issuance of a variance for areas prone to flooding.* Delete in its entirety.

*R112.3 Qualifications.* Delete in its entirety.

*R113.4 Violation penalties.* Any person who shall violate a provision of this code or shall fail to comply with any of the requirements thereof, shall be guilty of a misdemeanor and upon conviction thereof, shall be punished by a fine of not more than one thousand dollars (\$1,000.00) or by imprisonment not exceeding one (1) year, or by both such fine and imprisonment. Each day that a violation continues shall be deemed a separate offense.

*R202 Definitions. Accessory Structure.* A structure not greater than three thousand (3,000) square feet (279m) in floor area, and not over three (3) stories or exceeding twenty-four (24) feet in height with separate means of egress, and shall not occupy more than thirty percent (30%) of the required rear yard, and shall not exceed the height of the main structure, the use of which is customarily accessory to and incidental to that of the dwelling(s) and which is located on the same lot.

*R202 Attic, Habitable.* Add: 4. The occupiable space is provided with an egress door in accordance with Section R311.2 or by a ramp in accordance with Section R311.8 or a stairway in accordance with Section R311.7.

*R202 Structure.* Add following exception:

*Exception:* For existing decks being replaced, the same size will not be considered a structure for zoning purposes.

*Table 301.2 (1).* The following values shall be inserted into Table R301.2 (1):

Ground Snow Load – 20; Wind Speed (mph) – 115; Topographic Effects – No, Weathering - Yes Severe; Frost Line Depth – Yes; 30-inches; Termite - Very Heavy; Winter Design Temperature - +4 Degrees Fahrenheit; Ice Barrier Underlayment Required – No; Flood Hazards - As regulated by City of Columbia Ordinance; Air Freezing Index - 0 to 1500; Mean Annual Temperature - 55 degrees Fahrenheit.

*Table R301.5.* Add note g.4. Must also include a vertical egress component.

*R302.1 Exterior walls.* Add exception # 6: A detached accessory garage or shed located not less than three (3) feet from any side lot line.

*R302.5.1* Delete "equipped with a self-closing device."

*R302.6 Dwelling/garage fire separation.* Replace one-half (1/2) inch gypsum board with five-eighth (5/8) inch gypsum board in referenced Table R302.6 Dwelling/garage fire separation. Add last sentence to paragraph of R302.6: The garage shall be completely separated from the residence and its attic area by means of five-eighth (5/8) inch gypsum board or equivalent applied to the garage side.

*R303.4 Mechanical ventilation.* The dwelling unit shall be provided with whole-house mechanical ventilation in accordance with Section M1507.3. Alternatively, an insulated duct from the outside connected to the return air or HVAC unit ahead of the filter with balancing damper may be provided. The duct size shall be based on the conditioned area the HVAC unit serves. The duct shall be four (4) inches in diameter for areas 1,500 square feet or less, six (6) inches in diameter for areas over 1,500 square feet and less than or equal to 2,400 square feet, and eight (8) inches in diameter for areas over 2,400 square feet.

*R303.6 Add Exception:* Bathroom exhaust fans may be exhausted into a soffit vent if composed of approved materials as determined by the building official.

*Figure 307.1 Water closet:* All water closets shall be spaced at least fifteen (15) inches from the centerline of the fixture to any wall or plumbing fixture, except the centerline of the water closet may be spaced twelve (12) inches if located next to a bathtub/shower.

*R311.7.5.1 Risers.* Change the first sentence to read: The maximum riser height shall be seven and seven-eighth (7-7/8) inches (200mm). The rest of the paragraph remains as stated.

*R311.7.5.1 Risers. Add Exception:* Closed risers are not required on exterior stairs where the riser is less than 10' above grade.

*R312.1.1 Where Required:* Add: Grassed or landscaped areas a minimum of three feet wide behind a retaining wall shall not be deemed a walking surface. Delete, "at any point within 36" horizontally to the edge of the open side."

*R312.2 Window fall protection.* Deleted in its entirety.

*R313.1 Townhouse automatic fire sprinkler systems.* Delete in its entirety.

*R313.2 One- and two-family dwelling automatic fire sprinkler systems.* Delete in its entirety.

*R313.3 Automatic fire sprinkler systems.* A builder of a single-family dwelling or residences or multi-unit dwellings of four (4) or fewer units shall offer to any purchaser, on or before the time of entering into the purchase contract, the option at the purchaser's cost to install or equip an automatic fire sprinkler system in the dwelling, residence or unit. Notwithstanding any other provision of law to the contrary, no purchaser of such a single-family dwelling, residence, or multi-unit dwelling shall be denied the right to choose or

decline to install an automatic fire sprinkler system in such dwelling or residence being purchased by any code, ordinance, rule, regulation, order or resolution by any county or other political subdivision. Pursuant to RSMo. § 67.281, the mandatory option for purchasers to have the right to choose and the requirement that the builders offer to purchasers the option to purchase an automatic fire sprinkler system in connection with the purchase of any single-family dwelling, residence, or multi-unit dwelling of four (4) or fewer units is hereby incorporated into the code.

*R314.4 Add to exception:* In alterations smoke alarms shall not be required to be interconnected if the dwelling is no more than two (2) stories.

*R314.6 Add Exception 3.:* Smoke alarms in alterations shall be permitted to be battery operated if the dwelling is no more than two (2) stories.

*R322 Flood Resistant Construction.* Section 29-22 of the Code of Ordinances applies. Delete section in its entirety.

*R401.1 Application. Add Exception:* Foundation repairs for one- and two-family dwellings shall not require geotechnical evaluation or structural calculations.

*Table R401.4.1 PRESUMPTIVE LOAD-BEARING VALUES OF FOUNDATION MATERIALS:* Load-Bearing pressure (pounds per square foot) column, change value for clay, sandy clay, silty clay, clayey silt, silt and sandy silt (CL, ML, MH, and CH) from 1,500 to 2,000 leaving footnote b.

*Figure R403.1(1) Concrete and Masonry foundation details.* A slab on ground with turned down footings shall have the following: a #4 reinforcement bar spaced a minimum of forty-eight (48) inches on centers to provide connection of footing to slab. The vertical rods shall extend to within four (4) inches of the bottom of the footing and be turned to provide a horizontal leg that extends a minimum of twelve (12) inches into the slab.

*R403.1.6 Foundation anchorage.* Add the following to the end of the section, prior to the Exceptions: The connection of the foundation walls to floors shall be per the alternatives labeled 1.1, 1.2, 1.3, 1.4, 2.1, 2.1, 3.1, 3.2 or 4.

*NOTE:* Drawings as stated above are on file in the office of the building official.

*R404.4 Retaining Walls.* Add to the end of the section: As an alternative, retaining walls may be built per Alternative 4 listed in the amendment of Section R403.1.6 with a six (6) foot dead man placed for lateral support at each end of the unsupported wall and at the spacing shown. The retaining wall must be drained per Figure 405.1 or equivalent.

*R405.1 Concrete or masonry foundations.* Drains shall be provided around all concrete or masonry foundations that retain earth and enclose habitable or usable spaces located below grade. Drainage tiles, gravel or crushed stone drains, shall be installed at or below the area to be protected and shall discharge by gravity or mechanical means into an

approved drainage system. Gravel or crushed stone drains shall extend at least one (1) foot (305 mm) beyond the outside edge of the footing and six (6) inches (152 mm) above the top of the footing and be covered with an approved filter membrane material and shall include a drain tile pipe surrounded with an approved filter membrane or the filter membrane shall cover the washed gravel or crushed rock covering the drain as shown in figure R405.1. The drain pipe can be placed directly on top of the footing. The top of open joints of the drainage tiles or perforated pipe shall be protected with strips of building paper, and the drainage tiles or perforated pipe shall be placed directly on the top of the footing or placed on a minimum of two (2) inches (51 mm) of washed gravel or crushed rock at least one size larger than the tile joint opening or perforation and covered with not less than six (6) inches (152 mm) of the same material. Foundation Drainage Figure R405.1 as adopted, shall be considered to satisfy the provisions of this subsection.

*NOTE:* Foundation Figure R405.1 as stated above, is on file in the office of the building official

*R602.3.1 Stud size, height and spacing.* Amend Exception 2. as follows:

2. Where snow loads are less than or equal to twenty-five (25) pounds per square foot, and the ultimate design wind speed is less than or equal to 130 mph, two (2) inch by six (6) inch studs supporting a roof load with not more than six (6) feet of tributary length shall have a maximum height of eighteen (18) feet where spaced at sixteen (16) inches on center, or twenty (20) feet where spaced at twelve (12) inches on center. Studs shall be a minimum No. 2 grade lumber. Alternatively two (2) inch by six (6) inch No. 2 grade studs supporting a roof and floor load with not more than ten (10) foot of tributary length shall have a maximum stud height of fourteen (14) feet.

*R802.3.1 Ceiling joist and rafter connections.* Add last sentence to second paragraph: Rafter ties shall be spaced not more than four (4) feet (1219 mm) on center.

*ADD: R802.11.1.3* Where energy bands are used and the sheathing does not extend to the nailer above the energy band, an uplift connection strap shall be placed every four (4) feet.

*N1101.3 Scope.* Add the following: The figure labeled 2015 Residential Energy Code Requirements Diagram is an approved alternative means of compliance.

*NOTE:* Drawing as stated above is on file in the office of the building official.

*N1102.2.9 (R402.2.9) Basement walls.* Amend first sentence as follows: Walls associated with finished basements shall be insulated from the top of the basement wall down to 10 feet (3048 mm) below grade or to the basement floor, whichever is less.

*N1102.4.1.2 Testing.* Amend first sentence as follows: “The building or dwelling unit shall be blower door tested as deemed necessary by the building official and verified as having an air leakage... .”

*N1102.4.4 Rooms containing fuel burning appliances.* Delete.

*N1103.5.2 (R403.5.2) Demand recirculation systems.* Delete.

*M1411.8 Locking access port caps.* Delete.

*M1501.1 Outdoor discharge.* List first exception as number 1. and add exception number 2. as follows:

2. Bathroom fan air may be exhausted into a soffit vent if composed of approved materials as determined by the building official.

*M1502.4.2 Duct installation.* Delete the following words from the last sentence: “...that protrude more than 1/8 inch (3.2 mm) into the inside of the duct”.

*M1507.2 Recirculation of air.* Add exception: Bathroom fan air may be exhausted into a soffit vent if composed of approved materials as determined by the building official.

*G2414.5.2 Copper tubing.* Replace second paragraph with: Copper pipe and copper tubing shall not be allowed for fuel gas piping systems.

*G2415.14 Piping underground beneath buildings.* Add to last sentence: Any underground gas piping allowed by this section shall only be approved for gas that is less dense than the atmospheric pressure and shall be installed in accordance with G2415.12.1.

*G2415.14.2* Delete in its entirety.

*G2417.4.1 Test pressure.* The test pressure to be used shall be not less than one and one-half (1.5) times the proposed maximum working pressure, but not less than thirty (30) psig, irrespective of design pressure. (Rest of section remains as stated.)

*G2419.4 Sediment trap.* Change "any length" to "3½" minimum length".

*P2602.1.2 Availability.* A potable public water supply system shall be considered available to a building when any portion of the property is located within two hundred twenty-five (225) feet of the public water main.

*P2603.4 Pipes through foundation walls.* Add the following: Alternatively, the sleeve may be sized in accordance with the sealing system manufacturer's published recommendations.

*P2603.5 Freezing.* A water, soil or waste pipe shall not be installed outside of a building, or concealed in outside walls, or in any place subjected to freezing temperature, unless adequate provision is made to protect such pipe from freezing by insulation, heat or both. Water pipes shall not be installed in an exterior wall cavity in one and two family dwellings. For purposes of this section exterior wall cavities shall mean all walls that rain can fall upon. Water service piping shall be installed below recorded frost penetration but not less than thirty (30) inches below grade.

*P2603.5.1 Sewer depth.* Is amended to read: Building sewers, including the portion of the building drain beyond the exterior wall, shall be a minimum of thirty (30) inches below finished grade at the point of septic tank connection. Building sewers shall be a minimum of thirty (30) inches below grade. Add: The building official may approve a lesser depth of the building drain portion if there are extraordinary circumstances (e.g., bedrock).

*P2604.3 Backfilling.* The second sentence shall read as follows: "Backfill shall be free from rocks, broken concrete and frozen chunks until the pipe is covered by not less than twelve (12) inches of tamped earth or granular material."

*P2605.1 Piping Support.* Footnote B to be used for water distribution piping only.

*P2705.1 #5 Water closets, lavatories and bidets.* Amend first sentence to read: "All water closets shall be spaced fifteen (15) inches from the centerline of the fixture to any wall or plumbing fixture except the centerline of the water closet may be spaced twelve (12) inches is located next to the bathtub/shower." Remainder of the paragraph is unchanged.

*P2903.5 Water hammer.* Add Exception: A water-hammer arrestor is not needed in water distribution systems using PEX piping or systems using a combination of PEX and copper.

*P2905 Heated Water Distribution Systems.* Delete entire section.

*P2906.9.1.3 CPVC/AL/CPVC pipe.* Amend first sentence as follows: "Joint surfaces shall be clean and free of moisture, and purple primer shall be applied."

*P2906.9.1.4 PVC plastic pipe.* A primer that conforms to ASTM F 656 shall be applied to PVC solvent-cemented joints. Purple primer shall be used below grade. Solvent cement for PVC plastic pipe conforming to ASTM D 2564 shall be applied to all joint surfaces. If purple primer is used, Section P2503 Inspections and Tests shall not be required.

*P3003.9.2 Solvent Cementing.* Delete exceptions. Add: If upon inspection the aboveground joints do not have purple primer, a water test shall be performed and inspected.

*P3008.1 Sewage backflow.* Delete last sentence.

*P3103.1 Roof extension.* Replace first sentence with the following: Open vent pipes that extend through a roof shall terminate not less than twelve (12) inches above the roof.

*P3111.1 Type of fixtures.* Add exception: Residential food waste grinders shall be allowed to discharge into a combination waste and vent system provided an air admittance valve is installed.

*P3113.1 Size of vents.* Add sentence to paragraph: At least one (1) vent shall be three (3) inch unreduced in size extending from the main building drain through the roof.

Except as stated in sections E3608.1.1 Exception, E3609.6.1 and E3609.7 of this ordinance, Chapters 34 through 43 of the 2012 International Residential Code are superseded by the requirements as stated in the 2011 National Electrical Code (NFPA 70-2011).

*E3608.1.1 Exception:* When a concrete-encased electrode and/or ground ring are not available for use in a grounding electrode system, a rod or other electrode as specified in E3608.1.4 Rod and pipe electrodes and 3608.1.5 Plate electrodes can be used as a substitute. The second rod electrode shall not be connected in series with the first rod electrode except where there exists a metal water pipe in contact with earth for ten (10) feet or more, for one- and two – family dwellings a single grounding electrode placed at the outside of the building at the nearest point of the service disconnect shall be permitted to fill the requirements of this section.

*E3609.6.1 Water Heater Bonding Jumper.* The interior metal water piping bonding shall include a bonding jumper between the hot and cold waterlines at the water heater fixture if the entire system is copper excluding the service.

*Appendix F, Radon Control Methods, Section AF101 Scope, AF101.1 General:* Is amended to read: This appendix contains requirements for new construction and shall apply without regard to zone designation in Figure AF101 and Table AF101(1).

*Appendix F, Radon Control Methods,* is amended by deleting subsection AF103.12 Power Source in its entirety.

*ISPSC Section 305 Outdoor swimming pool.* An outdoor swimming pool, including an in-ground, above-ground pool, hot tub or spa shall be surrounded by a barrier which shall comply with the following:

1. The top of the barrier shall be at least seventy-two (72) inches (1836 mm) above finished ground level measured on the side of the barrier which faces away from the swimming pool. The maximum vertical clearance between finished ground level and the barrier shall be two (2) inches (51 mm) measured on the side of the barrier which faces away from the swimming pool. Where the top of the pool structure is above grade, such as an above ground pool, the barrier may be at ground level, such as the pool structure, or mounted on top of the pool structure. Where the barrier is mounted on top



of the pool structure, the maximum vertical clearance between the top of the pool structure and the bottom of the barrier shall be four (4) inches (102mm).

*Exception:* The top of the barrier shall be at least forty-eight (48) inches (1219mm) above ground level measured on the side of the barrier which faces away from the swimming pool provided the swimming pool is equipped with a rigid safety cover complying with ASTM F 1346.

2. through 10. Same as stated in International Residential Code.

SECTION 2. The repeal of Article II of Chapter 6 of the Code of Ordinances, City of Columbia, Missouri, relating to the 2009 Edition of the International Residential Code for One- and Two-Family Dwellings shall not affect any offense or act committed or done or any penalty or forfeiture incurred before the effective date of this ordinance.

SECTION 3. This ordinance shall be in full force and effect from and after October 1, 2016.

PASSED this \_\_\_\_\_ day of \_\_\_\_\_, 2016.

ATTEST:

\_\_\_\_\_  
City Clerk

\_\_\_\_\_  
Mayor and Presiding Officer

APPROVED AS TO FORM:

\_\_\_\_\_  
City Counselor

SUPPORTING  
DOCUMENTS FOR  
THIS AGENDA ITEM

# ALTERNATIVE 1.1

## Joist Perpendicular to Wall W/ Brick

2015 IRC

Section R403.1.6 Foundation Anchorage

Section R404 Foundations and Retaining Walls

Section R404.1 Concrete and Masonry Foundation Walls

\*This figure is provided as an example. This is not an all inclusive list of code requirements.

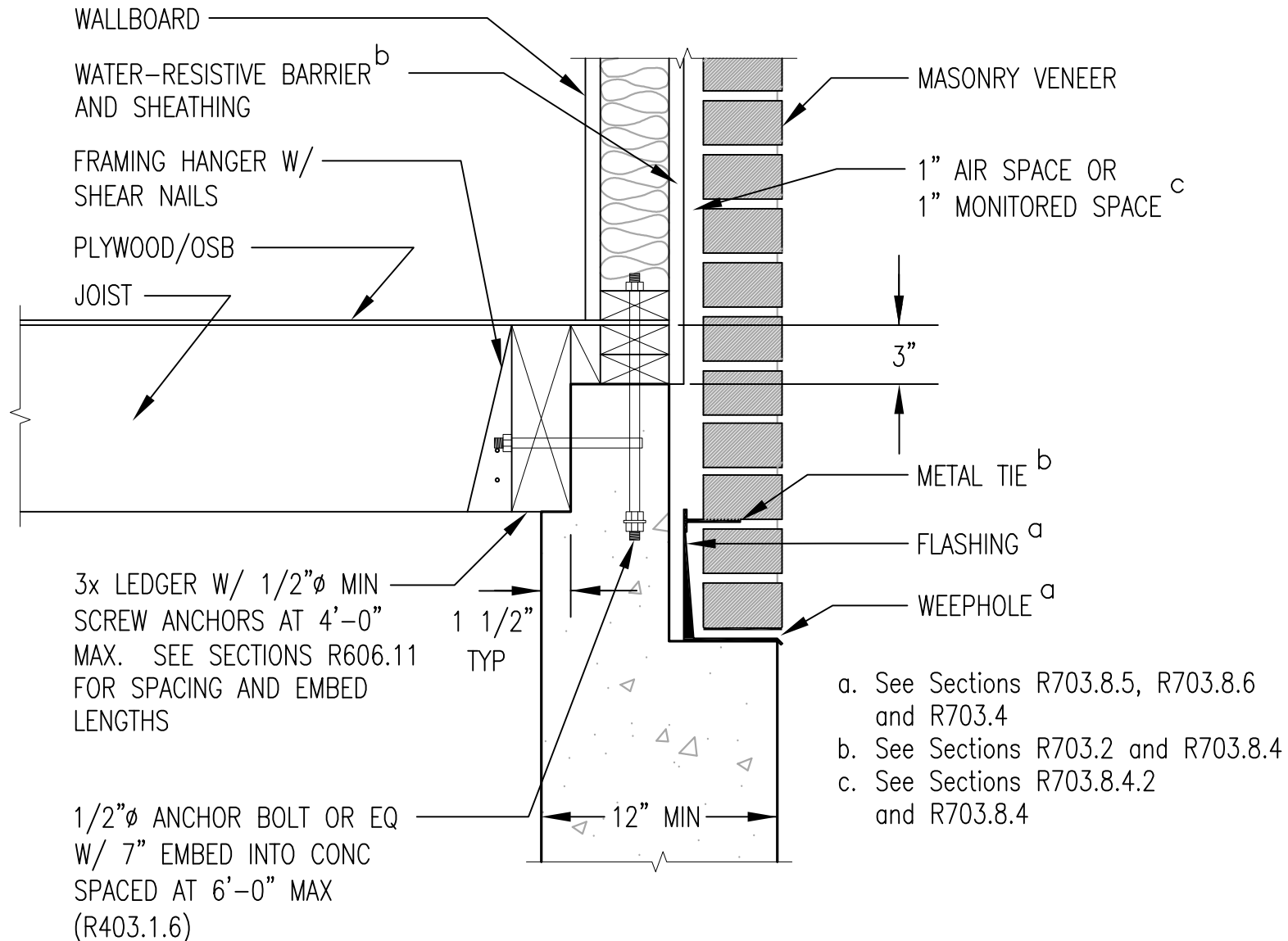

# ALTERNATIVE 1.2

## Joist Parallel to Wall W/ Brick

2015 IRC

Section R403.1.6 Foundation Anchorage

Section R404 Foundations and Retaining Walls

Section R404.1 Concrete and Masonry Foundation Walls

\*This figure is provided as an example. This is not an all inclusive list of code requirements.

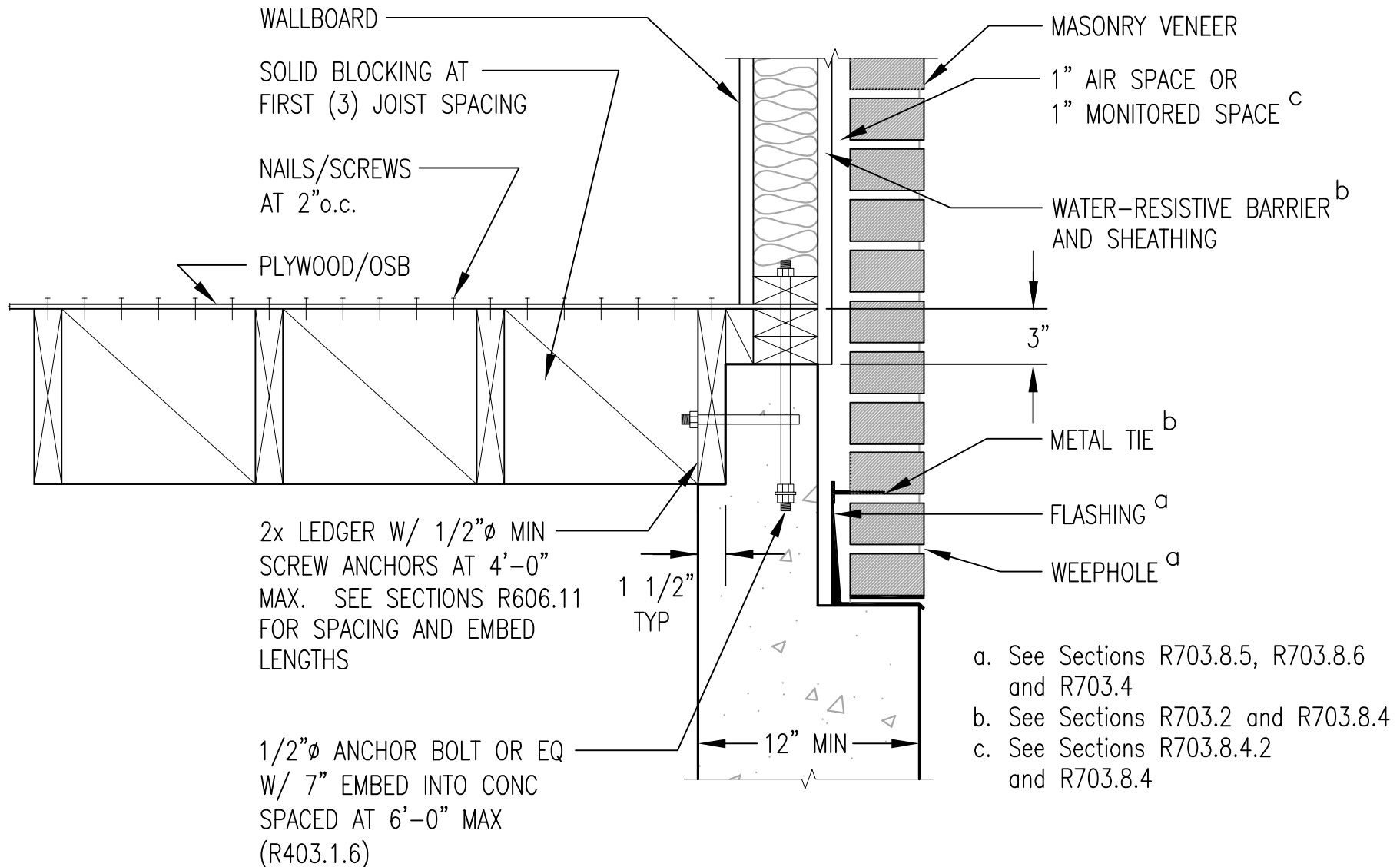

# ALTERNATIVE 1.3

## Joist Perpendicular to Wall W/O Brick

2015 IRC

Section R403.1.6 Foundation Anchorage

Section R404 Foundations and Retaining Walls

Section R404.1 Concrete and Masonry Foundation Walls

\* This figure is provided as an example. This is not an all inclusive list of code requirements.

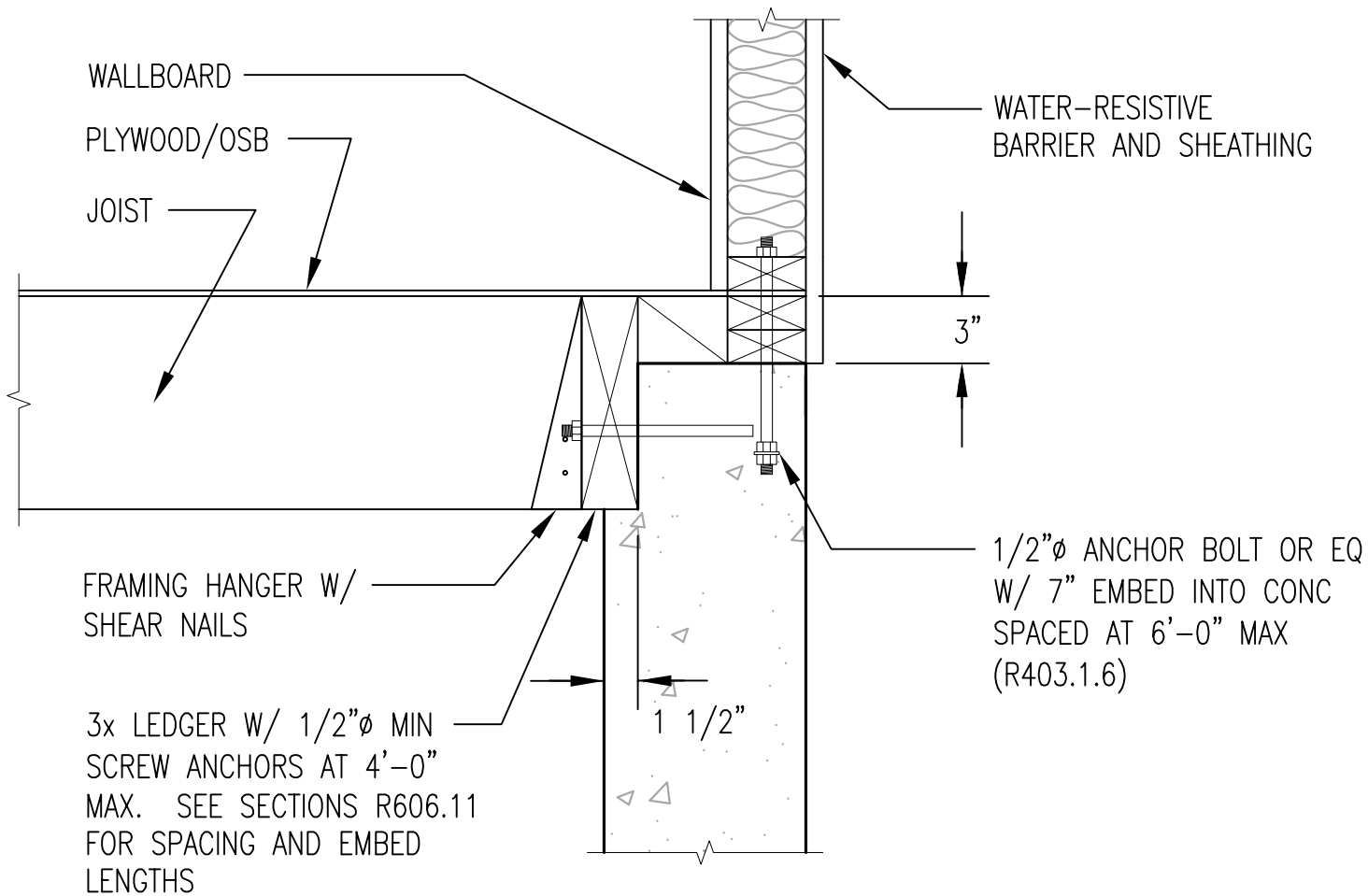

# ALTERNATIVE 1.4

## Joist Parallel to Wall W/O Brick

2015 IRC

Section R403.1.6 Foundation Anchorage

Section R404 Foundations and Retaining Walls

Section R404.1 Concrete and Masonry Foundation Walls

\* This figure is provided as an example. This is not an all inclusive list of code requirements.

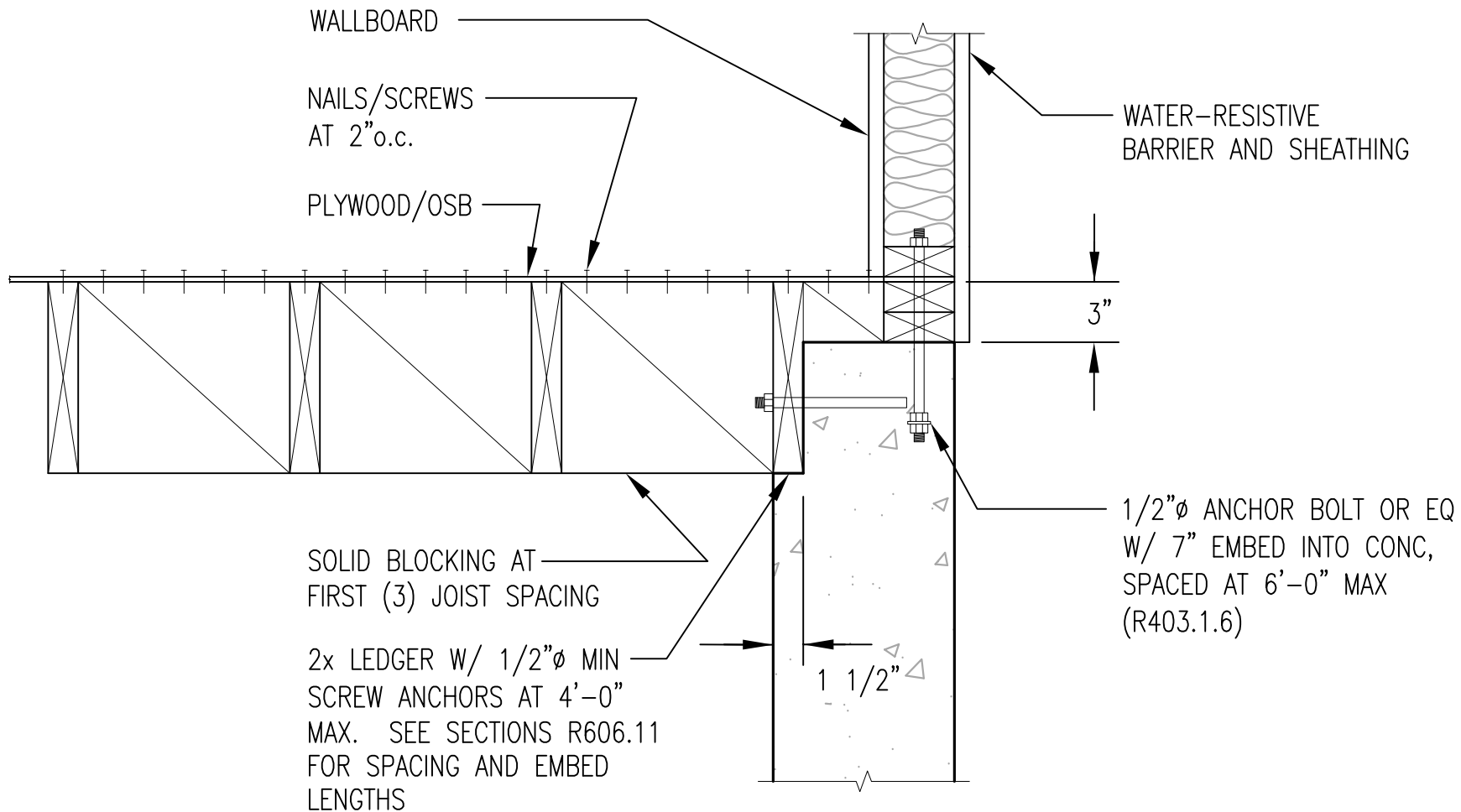

# ALTERNATIVE 2.1

## Joist Perpendicular to Wall

2015 IRC

Section R403.1.6 Foundation Anchorage

Section R404 Foundations and Retaining Walls

Section R404.1 Concrete and Masonry Foundation Walls

\* This figure is provided as an example. This is not an all inclusive list of code requirements.

NOTE A: Refer to the manufacturers tables for required spacing and placement of FWAZ wall angles

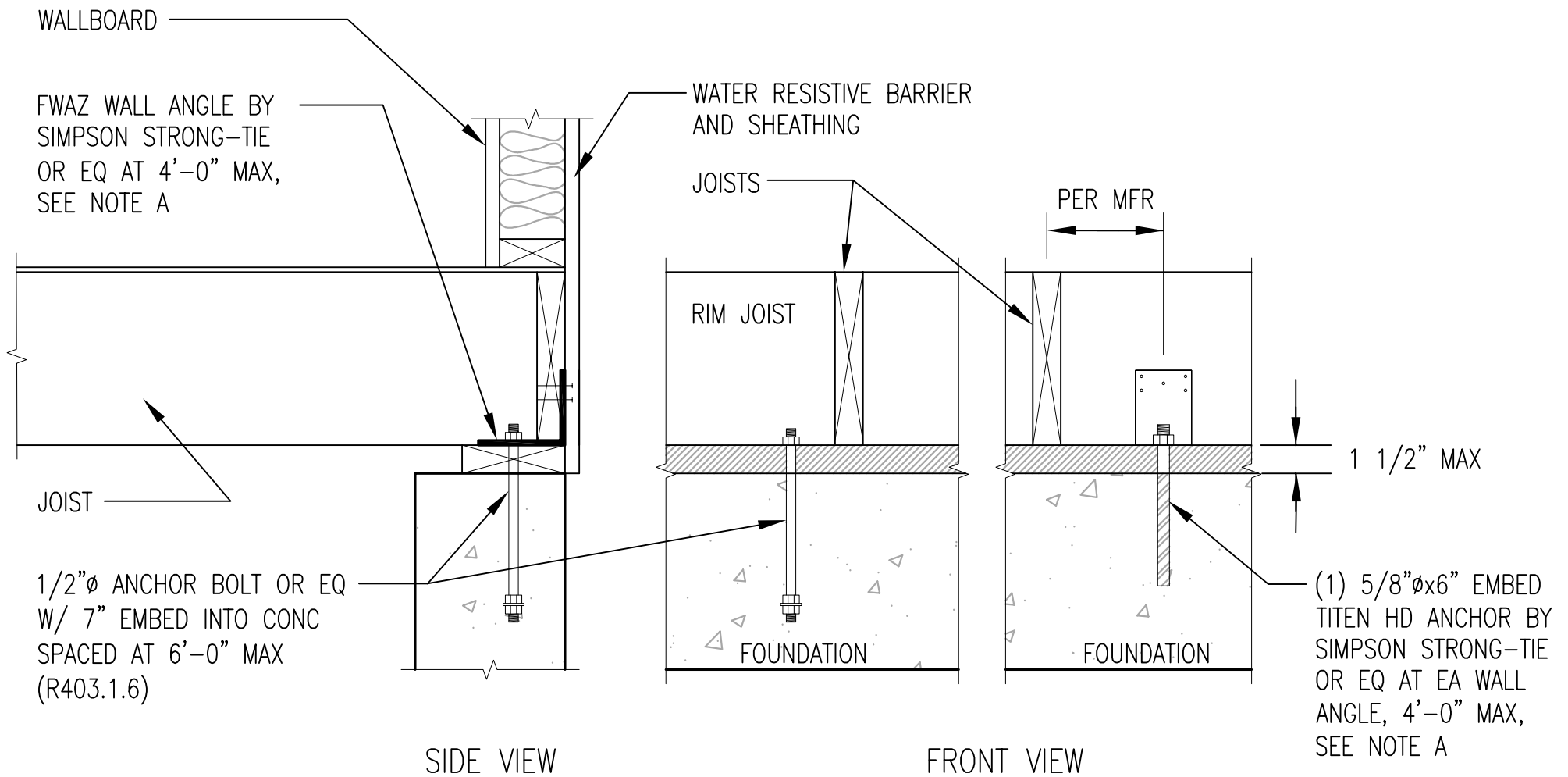

# ALTERNATIVE 2.2

## Joist Parallel to Wall

2015 IRC

Section R403.1.6 Foundation Anchorage

Section R404 Foundations and Retaining Walls

Section R404.1 Concrete and Masonry Foundation Walls

\* This figure is provided as an example. This is not an all inclusive list of code requirements.

NOTE A: Refer to the manufacturers tables for required spacing and placement of FWAZ wall angles

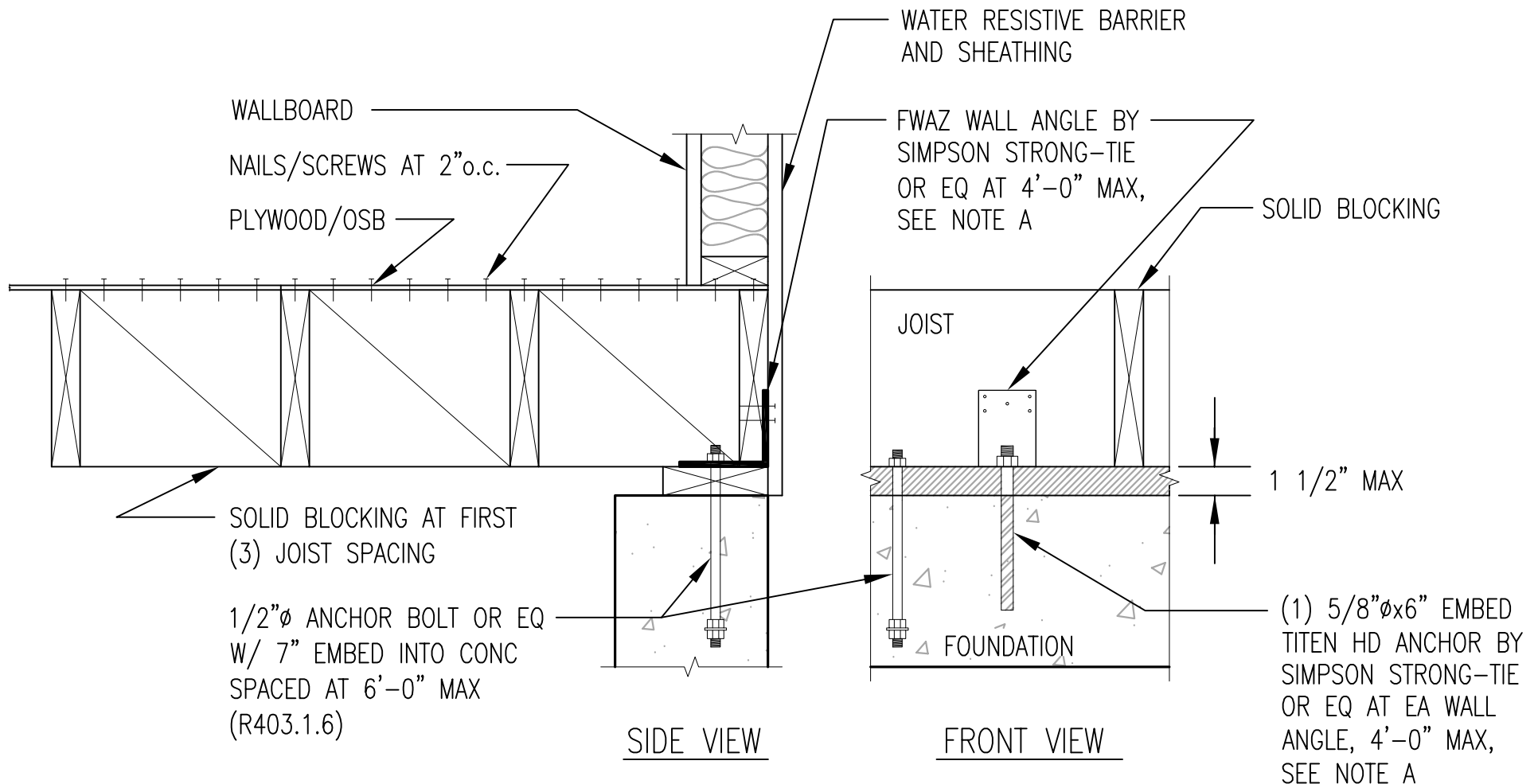



# ALTERNATIVE 3.1

## Joist Perpendicular to Wall W/O Brick

2015 IRC

Section R403.1.6 Foundation Anchorage

Section R404 Foundations and Retaining Walls

Section R404.1 Concrete and Masonry Foundation Walls

\* This figure is provided as an example. This is not an all inclusive list of code requirements.

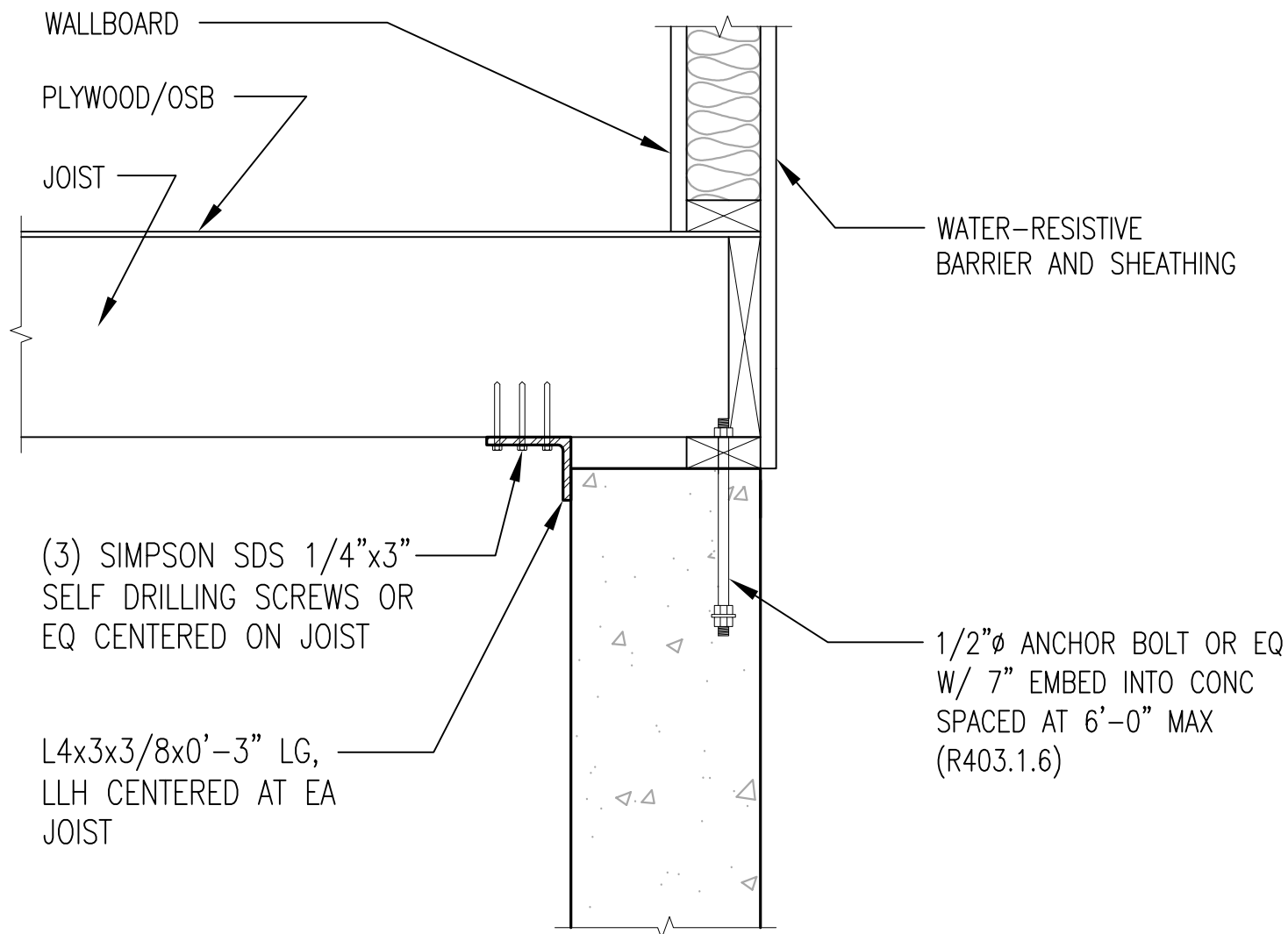

# ALTERNATIVE 3.2

## Joist Parallel to Wall W/O Brick

2015 IRC

Section R403.1.6 Foundation Anchorage

Section R404 Foundations and Retaining Walls

Section R404.1 Concrete and Masonry Foundation Walls

\* This figure is provided as an example. This is not an all inclusive list of code requirements.

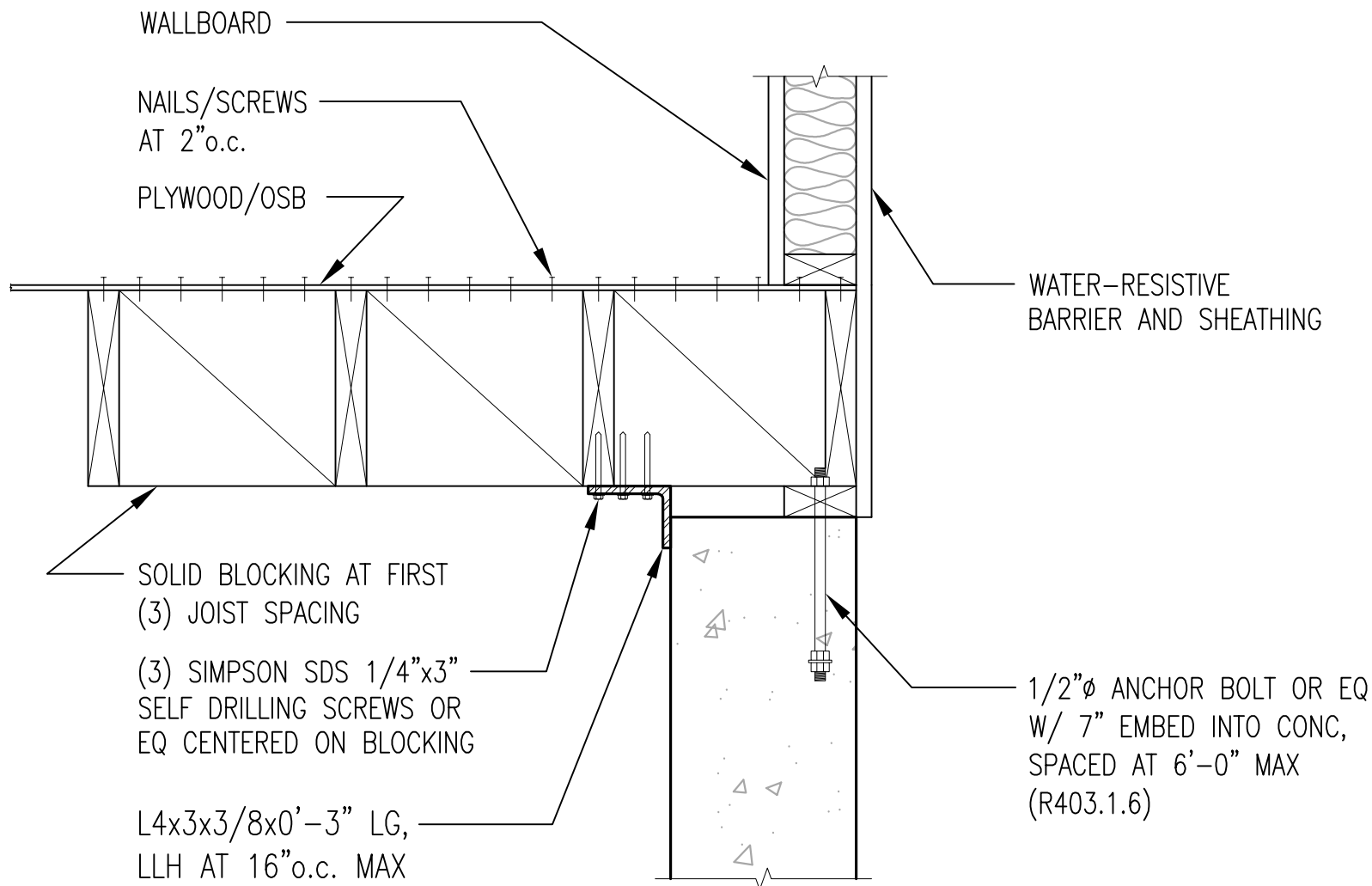

# ALTERNATIVE 4

2015 IRC

Section R403.1.6 Foundation Anchorage

Section R404 Foundations and Retaining Walls

Section R404.1 Concrete and Masonry Foundation Walls

\* This figure is provided as an example. This is not an all inclusive list of code requirements.

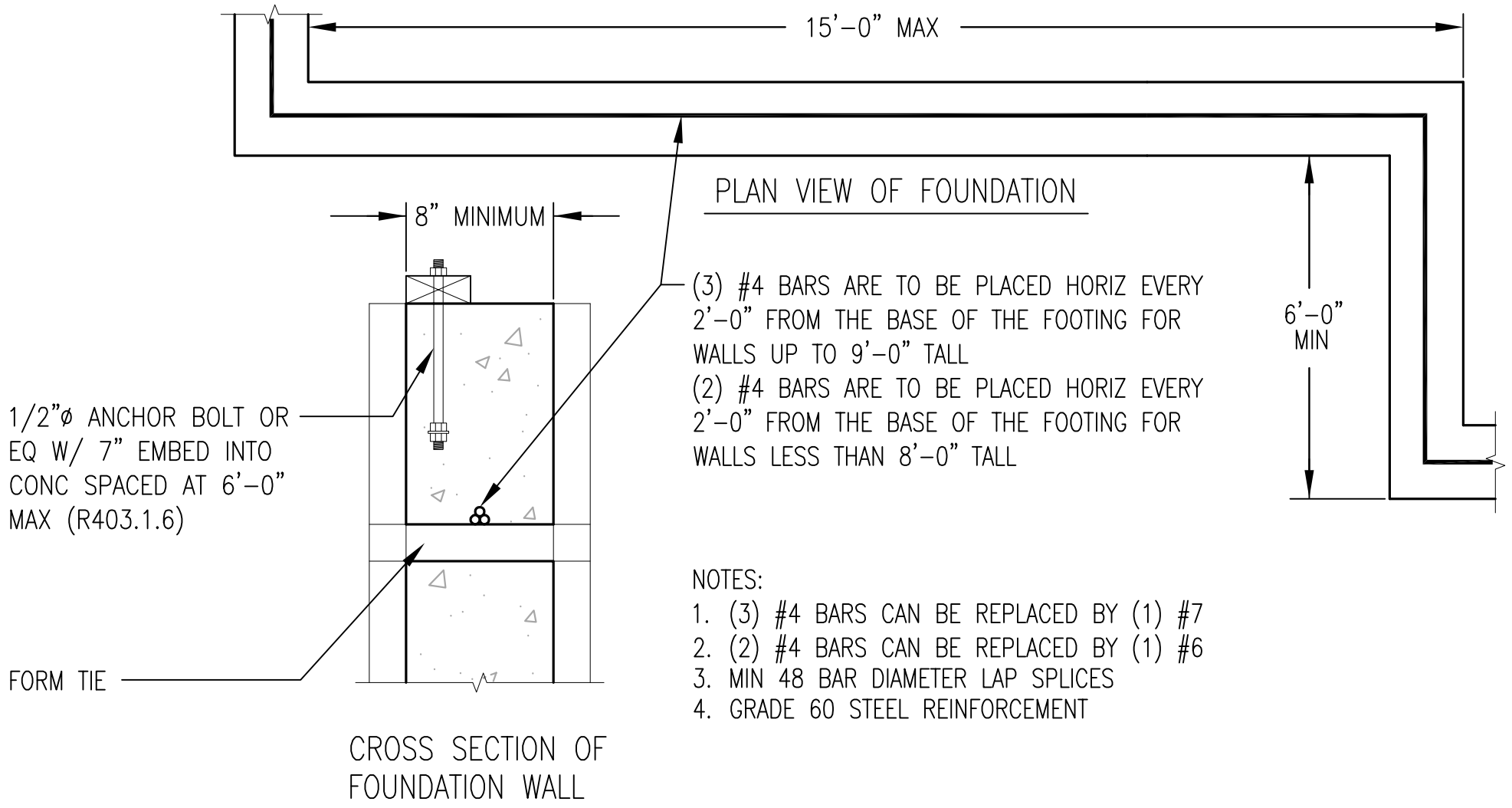

# FOUNDATION DRAINAGE

## FIGURE R405.1

2015 IRC

Section R405 Foundation Drainage

Section R406 Foundation Waterproofing and Dampproofing

- \* This figure is provided as an example. This is not an all inclusive list of code requirements.
- \*\* Either a filter fabric sock around draitile or filter fabric on the gravel shall be required, not both unless desired by the contractor.

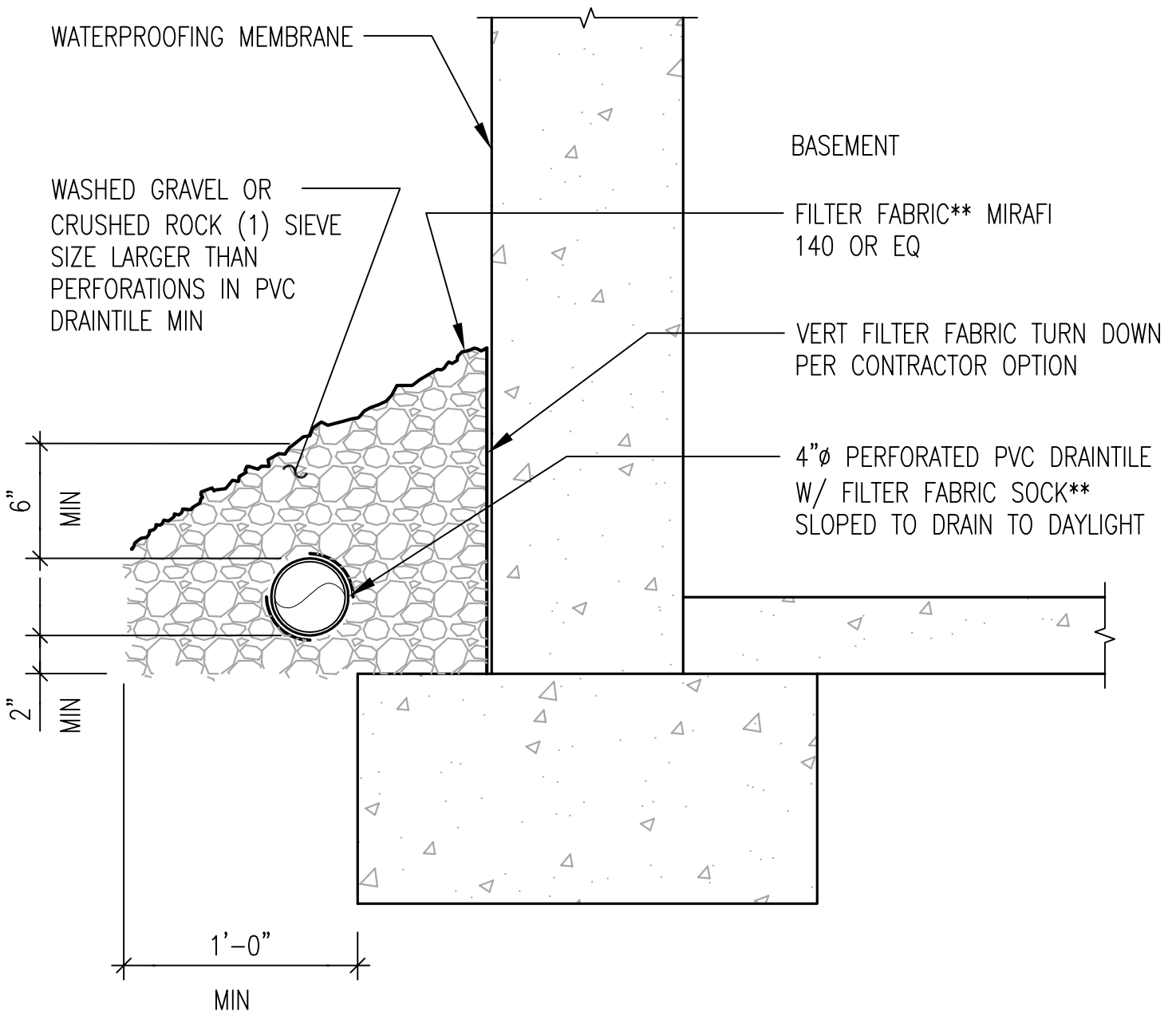

# City of Columbia, MO 2015 RESIDENTIAL ENERGY CODE REQUIREMENTS DIAGRAM

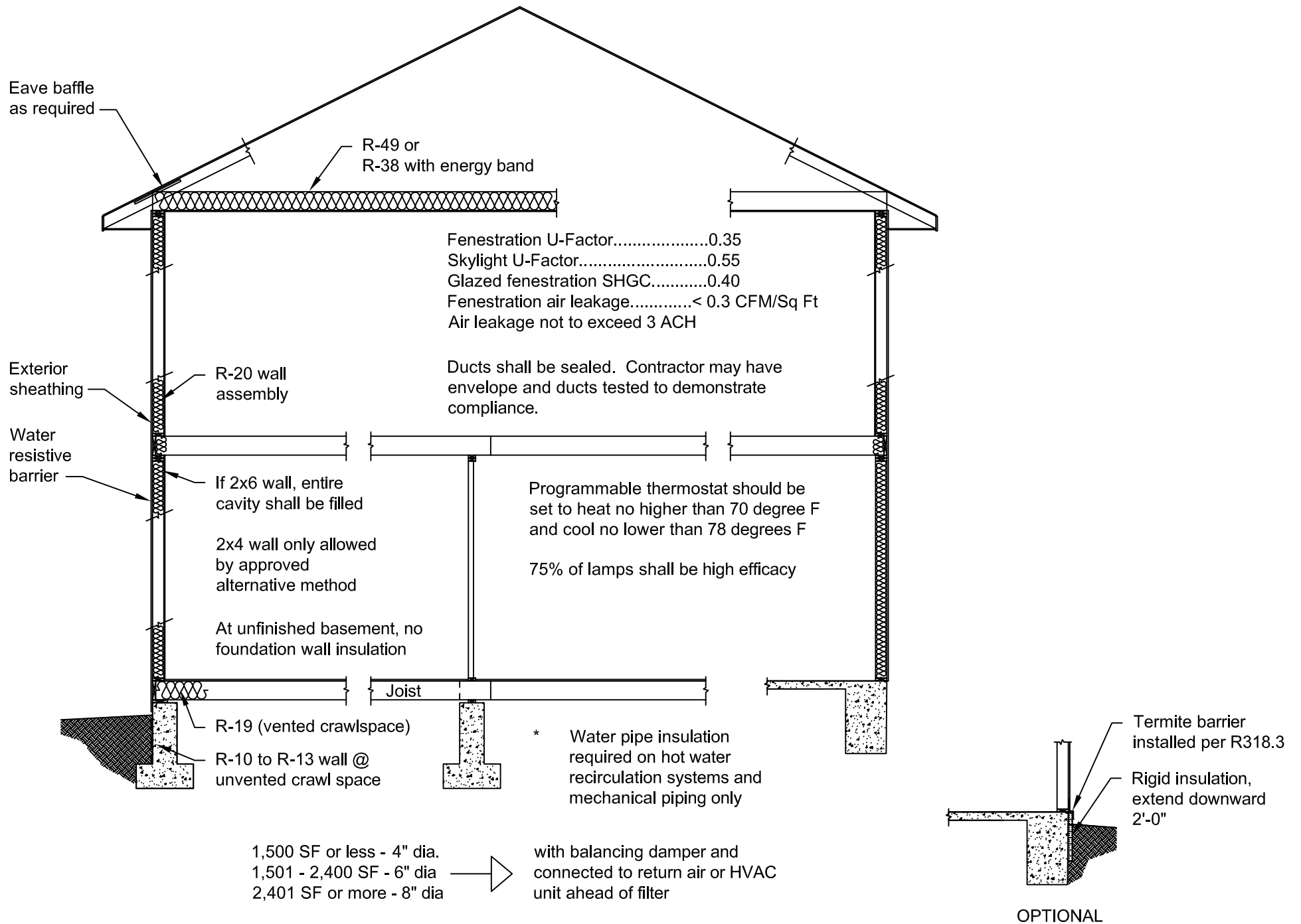

# ENVIRONMENT & ENERGY COMMISSION

City of Columbia & County of Boone  
City Hall, Conference Room 1A

February 23, 2016

Mayor McDavid and Council Members,

The Environment and Energy Commission (EEC) has reviewed the changes the Building Construction Codes Commission wants to make to the 2015 International Building Codes (IBC) before adoption. The EEC's concerns are with changes that have the effect of reducing the energy efficiency of buildings – thus increasing residents' energy costs. It's well known that climate change requires that we make changes to the way we build that conserve energy and help utilize different sources of energy. The 2015 IBC codes contain some changes that acknowledge the need for conservation and alternative energy sources.

The following points are addressed in detail in the attached report:

1. Require foundation insulation\*;
2. Require air tightness testing\*;
3. Require all residential buildings – even those classified as commercial (e.g. townhouses and apartment buildings) - to meet the residential energy efficiency requirements;
4. Require solar-ready construction.

The City of Columbia has made multiple commitments to sustainability (e.g. Mayor's Climate Protection Agreement, Renewable Energy Portfolio Standard, City of Columbia Strategic Plan, et. al.) and reducing energy efficiency is counter-productive to these commitments. We have much farther to go to address the issues that are predicated by climate change. The time to start is now. By adopting the 2015 IBC we save energy in Columbia.

Respectfully Yours,



Jan Dye

Chair

Environment and Energy Commission

\* = requirements under the 2012 City of Columbia-adopted International Building Codes that are weakened in the BCCC 2015 IBC proposal.

Attachments:

"EEC response to BCCC"

"IRC 2015 Ordinance + EEC comments"

"IBC 2015 Ordinance + EEC comments"

# EEC Energy Efficiency Recommendations

*The Building Codes Construction Commission (BCCC) has reviewed the 2015 International Building Codes and made some recommended changes to the code before adoption. The Energy and Environment Commission (EEC) does not recommend adopting changes to the code that have the effect of decreasing energy efficiency, or weaken previously adopted code designed to increase energy efficiency. In this document, the EEC has only addressed those BCCC recommendations which directly impact energy efficiency.*

## Foundation Insulation

BCCC recommends changing the termite infestation probability from “Moderate to Heavy” to “Very Heavy”. EEC disagrees with this recommendation for the following reasons:

- The 2015 International Residential Code has a map which shows Boone County is in the “Moderate to Heavy” termite region and a large distance from the “Very Heavy” region which is along the Gulf coast, *IRC Figure R301.2(6) TERMITE INFESTATION PROBABILITY MAP*, (attached).
- Changing the infestation probability for our region from “Moderate to Heavy” to “Very Heavy” gives credibility to the idea that foundations should be uninsulated to allow for easy viewing by termite inspectors.
- The City has received complaints from customers about winter electric bills of over \$400 per month.
  - Columbia Water and Light found these higher energy costs to be primarily a result of uninsulated foundations in slab floored rentals.
  - Slab insulation increases energy efficiency by 15%.
  - Structures built with uninsulated foundations do represent an initial reduced cost for the building but significantly increases costs for consumers because of reduced energy efficiency.

**The 2012 International Building Code, which was previously adopted by the City, contains section R318.3 which describes a solution to the problem of termite infestation being hidden by insulation. This section requires foundation insulation with termite shields. The EEC recommends that no changes be made to existing codes that remove the requirement for slab floor foundation insulation with termite shields.**

## Air Tightness Testing

Demonstrating compliance by testing for air infiltration (blower door test) and duct leakage test is required by IBC. In several places BCCC has recommended changing “shall” to “should,” or similar intent, regarding testing and documentation. The EEC disagrees with these recommendation for the following reasons:

- Very few builders will demonstrate their compliance with the provisions of the 2015 code. The rationale that BCCC uses is that “when constructed per the prescriptive code requirements the ... test is unnecessary.” But the inspections process for air infiltration and ducts is a process in which it is difficult to identify all of the possible problems during the normal inspection process.
- The EEC is willing to assume that the 2015 International Building Code had reason for recommending the tests and that the provisions of the Code should be adopted and followed in Columbia.
- The blower door and duct tests were adopted when the 2012 International Building Code was passed. Changes suggested by BCCC represent a reduction in efficiency standards from current requirements.

Some individuals believe that if the blower door test passes requirements there is no need for a duct test. EEC feels that this is in error for the following reasons:

- There can be large leakage in ducts outside of conditioned space which though they influence the blower door test will not cause it to fail since the size of duct connections are such a small portion of the possible air leakage into the house.
- Significant duct leakage, which occurs within the conditioned space, prevents conditioned air from reaching the more distant rooms and results in occupants adjusting the thermostat setting in order to be comfortable in those more distant rooms. Air in ducts is air on which money has just been spent so that the residence can be comfortable. It is clearly the most expensive air.



## Residential Energy Efficiency

The BCCC has supplied a figure titled 2015 RESIDENTIAL ENERGY CODE REQUIREMENTS DIAGRAM to simplify understanding of their proposed reductions in energy efficiency requirements. The figure is helpful but makes several reductions in the energy efficiency standards adopted with the 2012 International Building Code. The EEC recommends changes to the diagram for those items which delete the energy efficiency provisions to maintain the code standards the City adopted with the 2012 International Building Code. An amended diagram is attached.

*Specific changes to the diagram:*

### Item 1

“Ducts shall be sealed. Contractor may have envelope and ducts tested to demonstrate compliance.”

#### **To be replaced with:**

“Ducts shall be sealed. Envelope (blower door test) and duct testing are required to demonstrate compliance.”

The specific references in the International Code are:

- R402.4 Air leakage (Mandatory)
- R402.4.1.2 Testing The building or dwelling unit shall be tested and verified as having an air leakage rate not exceeding ... three air changes per hour in Climate Zones 3 through 8. (Columbia is in Climate Zone 4.)
- N1102.4.1.2 (R402.4.1.2) Testing; The building or dwelling unit shall be blower door and verified as having an air leakage...
- R403.3.3 Duct leakage.(Mandatory) Ducts shall be pressure tested to determine air leakage...

### Item 2

Under the diagram labeled “Termite barrier installed per R318.3, rigid insulation, extend down 2’-0” the word “OPTIONAL” occurs.

**OPTIONAL** should be replaced with **REQUIRED**.

## Commercial Residential Energy Efficiency

Some types of residential buildings fall under the International Commercial Building Code due to their use and density. Thus, a single-family residential home could have different energy efficiency requirements than another type of residential building. EEC recommends that all R1, R2, R3 and R4 zoned residential buildings be required to meet IBC 2015 Residential Energy Efficiency Code.

The IBC classification system should not be confused with Columbia's zoning classification despite use of the same codes lettering:

1. **R-4**  
5 to 16 persons plus custodial care staff in a supervised residential environment.
2. **R-3 non R-1, R-2, R-3, R-4**  
Typically transient or non-transient housing with 16 or fewer residents.
3. **R2**  
Apartments houses, non-transient hotels and motels, fraternities, sororities, dormitories and a few other residential types
4. **R-1**  
Primarily transient small, 10 or fewer transient occupant, housing.

EEC recommends that all R1, R2, R3 and R4 classified residential buildings be required to meet IBC 2015 **Residential** Energy Efficiency Code for the following reasons:

- Students and permanent Columbia residents who are low income and/or elderly are major consumers of housing that does not meet IBC residential efficiency standards..
- The modest savings on construction costs results in a burden of higher energy costs for consumers of these buildings. Keeping utility costs down is an important social equity component, and is part of Columbia's Strategic Plan. Increasing energy efficiency also reduces the rate at which we need to expand City utilities.
- In the International Building Code the residential energy efficiency code is for "one- and two-family dwellings, and multifamily dwellings (townhouses)."

The BCCC has proposed changes that redefine the insulation values for "commercial residential" units that changes energy efficiency for those housing units. (see table below)

Building Area	2015 IECC Table R402.1.2 Residential Code	BCCC Recommended	IRC 2015 IECC Table C402.1.3 Commercial Code
<b>Required Insulation Values</b>			
Ceiling or roof	R49	R38	R38
Exterior wall	R20 or 13+5	R15.5	R13+R3.8 or R20
Floor above crawlspace and ducts in ventilated attic and crawl space	R19	R19	R30
Walls separating garages and other internal but unheated space	R13		R13
Ducts in unheated areas not exposed to outside ventilation	R4	R4	R6 (C403.2.9)
Slab insulation	R10, 2 ft.	Omitted	R10, 2 ft.

## Solar Ready

BCCC does not recommend adopting the optional ordinance to require Solar Ready building design. The EEC disagrees for the following reason:

- Solar Ready sets standards for roof design which are minor changes from existing roofs and simply require a portion of the roof to be built without obstructions which would interfere with installing photovoltaic systems in the future.
- This should have very little impact on construction costs as it merely requires that the design takes solar into consideration.
- In the future, a larger portion of our electricity will need to come from solar power. The City of Columbia should encourage home owners to install it, and provide a building code that supports efforts to generate and use solar power.

## 2015 RESIDENTIAL ENERGY CODE REQUIREMENTS DIAGRAM

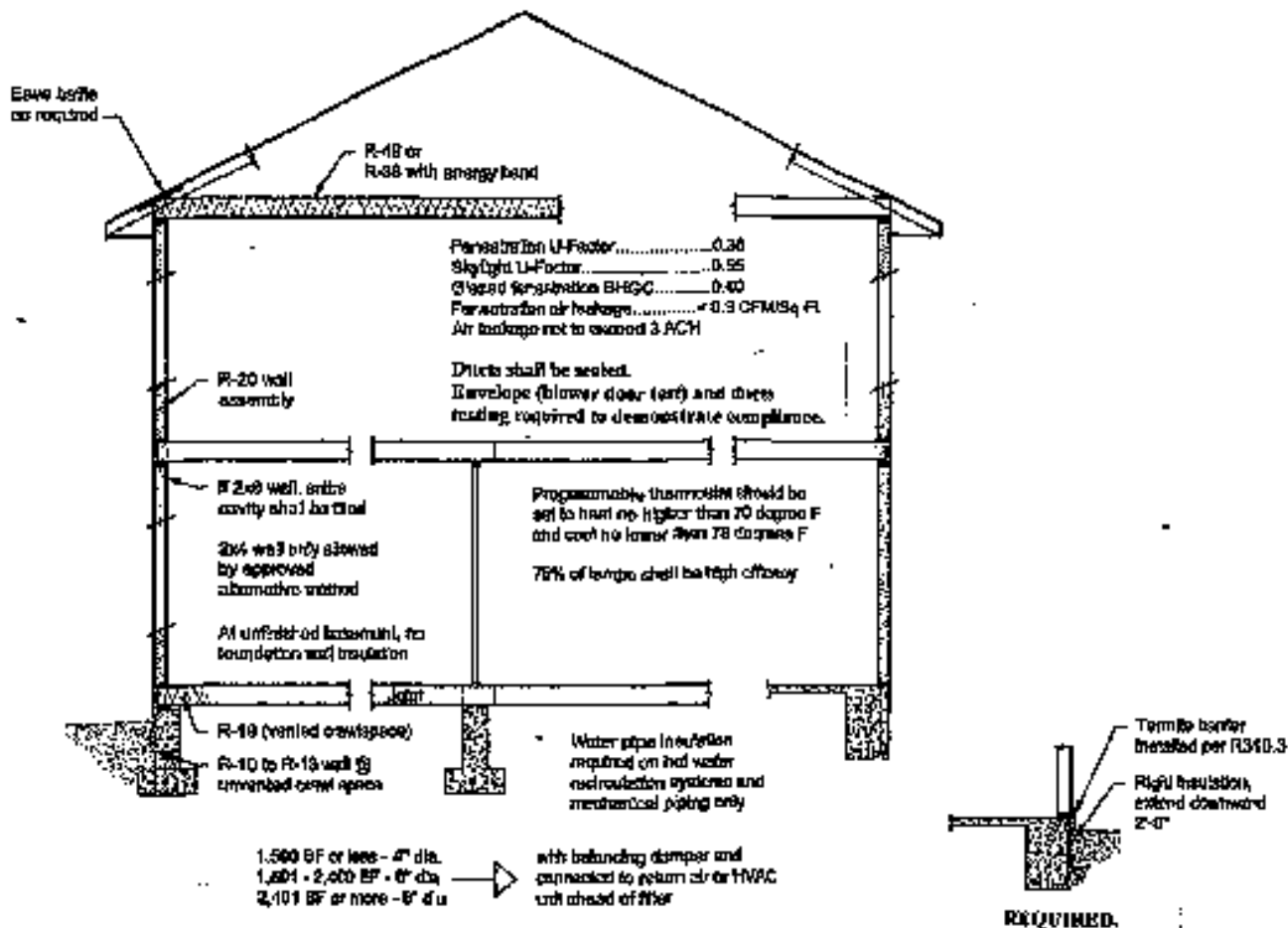

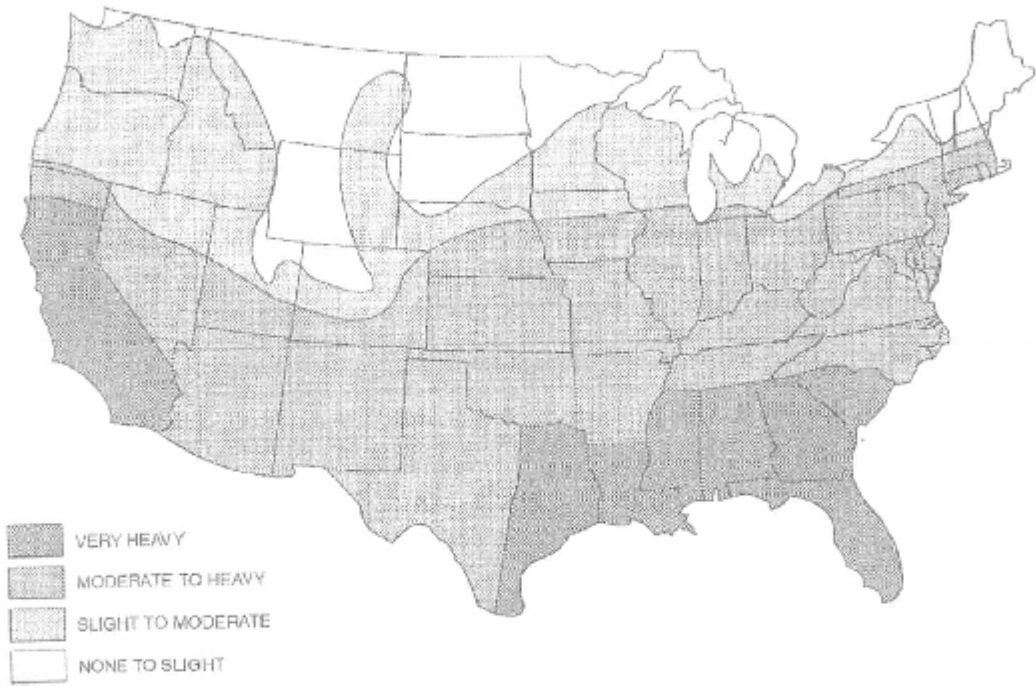

Note: Lines defining areas are approximate only. Local conditions may be more or less severe than indicated by the region classification.

FIGURE R301.2(6)  
TERMITE INFESTATION PROBABILITY MAP

**Energy & Environment Commission**

The Energy and Environment Commissions disagrees with some of the changes to this set of building codes proposed by Building Construction Codes Commission. The changes EEC objects to are struck-through with EEC proposed change(s) next to the struck-through text in bold red

Ordinance No. \_\_\_\_\_

Council Bill No. \_\_\_\_\_

**AN ORDINANCE**

Repealing Article VI of Chapter 6 of the City Code relating to the 2012 Edition of the International Residential Code for One- and Two-Family Dwellings and enacting in lieu thereof a new Article VI adopting the 2015 Edition of the International Residential Code for One- and Two-Family Dwellings; and fixing the time when this ordinance shall become effective.

BE IT ORDAINED BY THE COUNCIL OF THE CITY OF COLUMBIA, MISSOURI, AS FOLLOWS:

SECTION 1. Article VI of Chapter 6 of the Code of Ordinances, City of Columbia, Missouri, relating to the 2012 Edition of the International Residential Code for One- and Two-Family Dwellings, is hereby repealed and in lieu thereof a new Article VI, relating to the 2015 Edition of the International Residential Code for One- and Two-Family Dwellings, is hereby enacted reading in words and figures as follows:

**CHAPTER 6. BUILDINGS AND BUILDING REGULATIONS**

...

**Article VI. ONE- AND TWO-FAMILY DWELLING CODE**

Sec. 6-65. Adopted.

The 2015 Edition of the International Residential Code for One- and Two-Family Dwellings, published by the International Code Council, Inc., including Appendices A, B, C, E, F, G, H, K, and N, one copy of which has been on file with the city clerk for a period of ninety (90) days prior to the adoption of this article, is hereby adopted by reference and made a part of the Code of Ordinances, City of Columbia, Missouri as fully as if set forth in its entirety. At least one (1) copy of the 2015 Edition of the International Residential Code for One- and Two-Family Dwellings shall remain on file in the office of the city clerk and shall be kept available for public use, inspection and examination.

Sec. 6-66. - Amendments.

The code adopted by this article is hereby amended by substituting the following sections in lieu of those sections with corresponding numbers in the code, or, where there is no corresponding section in the code, the following sections shall be enacted as additions to the code:

R101.1 Title: These provisions shall be known as the Residential Code for One- and Two-Family Dwellings of the City of Columbia, and shall be cited as such and will be referred to herein as “this code.”

R102.5.1 Appendices A, B, C, E, F, G, H, K and N are hereby adopted as published.

R103.1 Creation of enforcement agency: Delete in its entirety.

R103.2 General: The building official is hereby authorized and directed to administer and enforce all provisions of this code. The building official shall be the director of community development.

R104.10.1 Flood Hazard Areas: Delete in its entirety.

R105.1 Permits required. Add to paragraph: All building, electrical, plumbing, mechanical and fuel gas permits may be issued to the general contractor, on behalf of master electrical, master mechanical, and master plumbing contractors, for new one- and two-family dwellings and building alteration or building additions to one- and two-family dwellings. All electrical, mechanical, plumbing and fuel gas work must be performed by trade contractors licensed by the City of Columbia for the appropriate trade or as allowed by ordinance.

**Vacant lot areas left from demolition shall be filled, leveled and graded to prevent ponding. The lot shall be left in a natural buildable condition without hazards, and mowable. There shall be sufficient vegetative cover to prevent erosion. The complete structure shall be removed and all accessory structures are to be removed at the time of demolition of the primary structure.**

R105.2, No. 2: Fences not over twelve (12) feet high.

**R106.2 Add paragraph. More than two single family dwellings, multiple duplexes, and/or townhomes on one lot shall require commercial civil/site documents per IBC 107.2.5 (including Columbia Code of Ordinances amendment), sealed by a professional engineer licensed in the State of Missouri.**

R109.1.6.1 Elevation Documentation: Deleted.

R112.1 General: Any aggrieved person shall have the right to appeal a decision of the code official to the building construction codes commission. Applications for appeal shall be filed in accordance with the procedures set out in Section 113 of the Building Code of Columbia, Missouri.

R112.2.1 Determination of substantial improvements in areas prone to flood: Delete in its entirety.

R112.2.2 Criteria for issuance of a variance for areas prone to flooding: Delete in its entirety.

R112.3 Qualifications: Delete in its entirety.

R113.4 Violation penalties: Any person who shall violate a provision of this code or shall fail to comply with any of the requirements thereof, shall be guilty of a misdemeanor and upon conviction thereof, shall be punished by a fine of not more than one thousand dollars (\$1,000.00) or by imprisonment not exceeding one (1) year, or by both such fine and imprisonment. Each day that a violation continues shall be deemed a separate offense.

R202 Definitions: Accessory Structure. A structure not greater than three thousand (3,000) square feet (279m) in floor area, and not over three (3) stories or exceeding twenty-four (24) feet in height with separate means of egress, and shall not occupy more than thirty percent (30%) of the required rear yard, and shall not exceed the height of the main structure, the use of which is customarily accessory to and incidental to that of the dwelling(s) and which is located on the same lot.

R202: Add: Attic, Habitable. Add: 4. The occupiable space is provided with an egress door in accordance with Section R311.2 or by a ramp in accordance with Section R311.8 or a stairway in accordance with Section R311.7.

**R202 Definitions: Structure. Add exception for existing decks being replaced the same size will not be considered a structure for zoning purposes.**

Table 301.2 (1): The following values shall be inserted into Table R301.2 (1):

Ground Snow Load – 20; Wind Speed (mph) – **115**; Topographic Effects – No, Weathering - Yes Severe; Frost Line Depth – Yes; 30-inches; Termite - ~~Very Heavy~~ **Moderate to Heavy**;

Winter Design Temperature - +4 Degrees Fahrenheit; Ice Barrier Underlayment Required – No; Flood Hazards - As regulated by City of Columbia Ordinance; Air Freezing Index - 0 to **1500**; Mean Annual Temperature - 55 degrees Fahrenheit.

Table R301.5: Add note g.4. Must also include a vertical egress component.

R302.1 Exterior walls: Add exception # 6: A detached accessory garage or shed located not less than three (3) feet from any side lot line.

R302.5.1 Delete "equipped with a self-closing device."

R302.6 Dwelling/garage fire separation: Replace one-half (½) inch gypsum board with five-eighth (5/8) inch gypsum board in referenced Table R302.6 Dwelling/garage fire separation. Add



last sentence to paragraph of R302.6: The garage shall be completely separated from the residence and its attic area by means of five-eighth (5/8) inch gypsum board or equivalent applied to the garage side.

**R303.4 Mechanical ventilation. The dwelling unit shall be provided with whole-house mechanical ventilation in accordance with Section M1507.3. Alternatively an insulated duct from the outside connected to the return air or HVAC unit ahead of the filter with balancing damper may be provided. The duct size shall be based on the conditioned area the HVAC unit serves. The duct shall be 4" diameter for areas 1,500 S.F. or less, 6" diameter for areas over 1,500 S.F. and less than or equal to 2,400 S.F., and 8" diameter for areas over 2,400 S.F.**

R303.6 Add Exception: Bathroom exhaust fans may be exhausted into a soffit vent if composed of approved materials as determined by the building official.

**Figure 307.1** Water closet: All water closets shall be spaced at least fifteen (15) inches from the centerline of the fixture to any wall or plumbing fixture, except the centerline of the water closet may be spaced twelve (12) inches if located next to a bathtub/shower.

R311.7.5.1 Risers: Change the first sentence to read: The maximum riser height shall be seven and seven-eighth (7 7/8") inches (200mm). The rest of the paragraph remains as stated.

R311.7.5.1 Risers: Add Exception: Closed risers are not required on exterior stairs where the riser is less than 10' above grade.

R312.1.1 Where Required: Add: Grassed or landscaped areas a minimum of three feet wide behind a retaining wall shall not be deemed a walking surface. **Delete, "at any point within 36" horizontally to the edge of the open side."**

R312.2 Deleted in its entirety. **Window fall protection**

R313.1 Townhouse automatic fire sprinkler systems. Delete in its entirety.

R313.2 One-and two-family dwelling automatic fire sprinkler systems. Delete in its entirety.

***R313.3 Automatic Fire Sprinkler Systems: A builder of a single-family dwelling or residences or multi-unit dwellings of four (4) or fewer units shall offer to any purchaser on or before the time of entering into the purchase contract the option at the purchaser's cost to install or equip an automatic fire sprinkler system in the dwelling, residence, or unit. Notwithstanding any other provision of law to the contrary, no purchaser of such a single-family dwelling, residence, or multi-unit dwelling shall be denied the right to choose or decline to install an automatic fire sprinkler system in such dwelling or residence being purchased by any code, ordinance, rule, regulation, order or resolution by any county or other political subdivision. Pursuant to RSMo § 67.281, the mandatory option for purchasers to have the right to choose and the requirement that the builders offer to purchasers the option to purchase an automatic fire sprinkler system in connection with the purchase of any single-family dwelling, residence, or multi-unit dwelling of four (4) or fewer units is hereby incorporated into the code.***

**R314.4 Add to exception, “In alterations smoke alarms shall not be required to be interconnected if the dwelling is no more than 2 stories.”**

**R314.6 Add exception #3, “Smoke alarms in alterations shall be permitted to be battery operated if the dwelling is no more than 2 stories.”**

R322.1 General: Section 29-22 of the Code of Ordinances applies. Delete the rest of section R322 Flood-Resistant Construction in its entirety.

R401.1 Application: Add Exception: Foundation repairs for one- and two-family dwellings shall not require geotechnical evaluation or structural calculations.

Table R401.4.1 PRESUMPTIVE LOAD-BEARING VALUES OF FOUNDATION

MATERIALS: Load-Bearing pressure (pounds per square foot) column, change value for clay, sandy clay, silty clay, clayey silt, silt and sandy silt (CL, ML, MH, and CH) from 1,500 to 2,000 leaving footnote b.

Figure R403.1(1) Concrete and Masonry foundation details: **A slab on ground with turned down footings** shall have the following: a #4 reinforcement bar spaced a minimum of forty-eight (48) inches on centers to provide connection of footing to slab. The vertical rods shall extend to within four (4) inches of the bottom of the footing and be turned to provide a horizontal leg that extends a minimum of twelve (12) inches into the slab.

**R403.1.6 Add to the end of the section just before the exceptions; The connection of the foundation walls to floors shall be per the alternatives labeled 1.1, 1.2, 1.3, 1.4, 2.1, 2.1, 3.1, 3.2, or 4.**

R404.4 Retaining Walls: **Add to the end of the section; As an alternative retaining walls may be built per alternative number 4 listed in the amendment of Section R403.1.6 with a 6 foot dead man placed for lateral support at each end of the unsupported wall and at the spacing shown. The retaining wall must be drained per figure 405.1 or equivalent.**

R405.1 Concrete or masonry foundations. Drains shall be provided around all concrete or masonry foundations that retain earth and enclose habitable or usable spaces located below grade. Drainage tiles, gravel or crushed stone drains, shall be installed at or below the area to be protected and shall discharge by gravity or mechanical means into an approved drainage system. Gravel or crushed stone drains shall extend at least one (1) foot (305 mm) beyond the outside edge of the footing and six (6) inches (152 mm) above the top of the footing and be covered with an approved filter membrane material and shall include a drain tile pipe surrounded with an approved filter membrane or the filter membrane shall cover the washed gravel or crushed rock covering the drain as shown in figure R405.1. The drain pipe can be placed directly on top of the footing. The top of open joints of the drainage tiles or perforated pipe shall be protected with strips of building paper, and the drainage tiles or perforated pipe shall be placed directly on the top of the footing or placed on a minimum of two (2) inches (51 mm) of washed gravel or crushed rock at least one size larger than the tile joint opening or perforation and covered with

not less than six (6) inches(152 mm) of the same material. Foundation Drainage Figure R405.1 as adopted, shall be considered to satisfy the provisions of this subsection.

NOTE: Foundation Figure R405.1 as stated above, is on file in the office of the building official

**Exception 2 Section R602.3.1 Amend as follows:**

Where snow loads are less than or equal to 25 pounds per square foot, and the ultimate design wind speed is less than or equal to 130 mph, 2-inch by 6-inch studs supporting a roof load with not more than 6 feet of tributary length shall have a maximum height of 18 feet where spaced at 16 inches on center, or 20 feet where spaced at 12 inches on center. Studs shall be a minimum No. 2 grade lumber. **Alternatively 2-inch by 6-inch No. 2 grade studs supporting a roof and floor load with not more than 10 foot of tributary length shall have a maximum stud height of 14 feet.**

R802.3.1 Ceiling joist and rafter connections: Add last sentence to second paragraph: Rafter ties shall be spaced not more than four (4) feet (1219 mm) on center.

**Add R802.11.1.3 Where energy bands are used and the sheathing does not extend to the nailer above the energy band an uplift connection strap shall be placed every 4 feet.**

**N1101.3 Scope. Add the following: The figure labeled 2015 Residential Energy Code Requirements Diagram is an approved alternative means of compliance.**

NOTE: Drawing as stated above is on file in the office of the building official.

**N1102.2.9 (R402.2.9) Basement walls. Amend first sentence as follows;** Walls associated with ~~conditioned~~ **finished** basements shall be insulated from the top of the basement wall down ....

**N1102.4.1.2 Testing; amend as follows;** “The building or dwelling unit shall be **blower door** tested ~~as deemed necessary by the building official~~ and verified as having an air leakage...”

**N1102.4.4 Rooms containing fuel burning appliances. Delete**

**M1411.8 Delete (Locking ports)**

M1501.1 Outdoor discharge: List first exception as number 1. and add exception number 2. **Bathroom fan** air may be exhausted into a soffit vent if composed of approved materials as determined by the building official.

**M1502.4.2 Delete portion of last sentence from “that protrude more than 1/8 inch (3.2 mm) into the inside of the duct.”**

M1507.2 Recirculation of air: Add exception: **Bathroom fan** air may be exhausted into a soffit vent if composed of approved materials as determined by the building official.

G2414.5.2 Copper tubing: Replace second paragraph with: Copper pipe and copper tubing shall not be allowed for fuel gas piping systems.

G2415.14 Add to last sentence: Any underground gas piping allowed by this section shall only be approved for gas that is less dense than the atmospheric pressure and shall be installed in accordance with G2415.12.1.

G2415.14.2 Delete in its entirety.

G2417.4.1 Test pressure: The test pressure to be used shall be not less than one and one-half (1.5) times the proposed maximum working pressure, but not less than thirty (30) psig, irrespective of design pressure. (Rest of section remains as stated.)

G2419.4 Sediment trap. Change "any length" to "3 1/2" minimum length"

P2602.1.2 Availability: A potable public water supply system shall be considered available to a building when any portion of the property is located within two hundred twenty-five (225) feet of the public water main.

P2603.4: Add the following: Alternatively, the sleeve may be sized in accordance with the sealing system manufacturer's published recommendations.

P2603.5 Freezing: A water, soil or waste pipe shall not be installed outside of a building, or concealed in outside walls, or in any place subjected to freezing temperature, unless adequate provision is made to protect such pipe from freezing by insulation, heat or both. Water pipes shall not be installed in an exterior wall cavity in one and two family dwellings. For purposes of this section exterior wall cavities shall mean all walls that rain can fall upon. Water service piping shall be installed below recorded frost penetration but not less than thirty (30) inches below grade.

P2603.5.1 Sewer depth: Is amended to read: Building sewers, **including the portion of the building drain beyond the exterior wall**, shall be a minimum of thirty (30) inches below finished grade at the point of septic tank connection. Building sewers shall be a minimum of thirty (30) inches below grade. **Add; The building official may approve a lesser depth of the building drain portion if there are extraordinary circumstances. (eg. Bedrock).**

P2604.3 Backfilling: Add to the end of the second sentence as follows; "Backfill shall be free from rocks, broken concrete and frozen chunks until the pipe is covered by not less than 12 inches of tamped earth **or granular material.**"

**P2605.1 Piping Support—Footnote B to be used for water distribution piping only.**

P2705.1 #5 Water closets, lavatories and bidets: Amend first sentence to read: All water closets shall be spaced fifteen (15) inches from the centerline of the fixture to any wall or plumbing

fixture except the centerline of the water closet may be spaced twelve (12) inches is located next to the bathtub/shower. Rest of the paragraph remains as stated.

P2903.5 Water hammer: Add exception: A water-hammer arrestor is not needed in water distribution systems using PEX piping or systems using a combination of PEX and copper.

**P2905 Heated Water Distribution Systems--Delete—Will require deletion of N 1103.5.2!**

**P2906.9.1.3 Amend first sentence as follows;** Joint surfaces shall be clean and free of moisture, and **purple** primer shall be applied.

**P2906.9.1.4** PVC plastic pipe. A primer that conforms to ASTM F 656 shall be applied to PVC solvent-cemented joints. Purple primer shall be used below grade. Solvent cement for PVC plastic pipe conforming to ASTM D 2564 shall be applied to all joint surfaces. If purple primer is used, Section P2503 ~~Inspections and~~ Tests shall not be required.

**P3003.9.2 Solvent Cementing. Delete exceptions. Add: If upon inspection the above ground joints do not have purple primer a water test shall be performed and inspected.**

P3008.1 Sewage backflow. Delete last sentence.

**P3103.1 Replace first sentence. Open vent pipes that extend through a roof shall terminate not less than 12 inches above the roof.**

P3111.1 Type of fixtures: Add exception: Residential food waste grinders shall be allowed to discharge into a combination waste and vent system provided an air admittance valve is installed.

P3113.1 Size of vents: Add sentence to paragraph: At least one (1) vent shall be three (3) inch unreduced in size extending from the main building drain through the roof.

Except as stated in sections E3608.1.1 Exception, E3609.6.1 and E3609.7 of this ordinance, Chapters 34 through 43 of the 2012 International Residential Code are superseded by the requirements as stated in the 2011 National Electrical Code (NFPA 70-2011). **Ask electricians**

E3608.1.1 Exception: When a concrete-encased electrode and/or ground ring are not available for use in a grounding electrode system, a rod or other electrode as specified in E3608.1.4 Rod and pipe electrodes and 3608.1.5 Plate electrodes can be used as a substitute. The second rod electrode shall not be connected in series with the first rod electrode except where there exists a metal water pipe in contact with earth for ten (10) feet or more, for one- and two – family dwellings a single grounding electrode placed at the outside of the building at the nearest point of the service disconnect shall be permitted to fill the requirements of this section.

E3609.6.1 Water Heater Bonding Jumper: The interior metal water piping bonding shall include a bonding jumper between the hot and cold waterlines at the water heater fixture if the entire system is copper excluding the service.

*Appendix F, Radon Control Methods, Section AF101 Scope, AF101.1 General:* Is amended to read: This appendix contains requirements for new construction and shall apply without regard to zone designation in Figure AF101 and Table AF101(1).

*Appendix F, Radon Control Methods,* is amended by deleting subsection AF103.12 Power Source in its entirety.

**ISPSC Section 305** Outdoor swimming pool: An outdoor swimming pool, including an in-ground, above-ground pool, hot tub or spa shall be surrounded by a barrier which shall comply with the following:

1. The top of the barrier shall be at least seventy-two (72) inches (1836 mm) above finished ground level measured on the side of the barrier which faces away from the swimming pool. The maximum vertical clearance between finished ground level and the barrier shall be two (2) inches (51 mm) measured on the side of the barrier which faces away from the swimming pool. Where the top of the pool structure is above grade, such as an above ground pool, the barrier may be at ground level, such as the pool structure, or mounted on top of the pool structure. Where the barrier is mounted on top of the pool structure, the maximum vertical clearance between the top of the pool structure and the bottom of the barrier shall be four (4) inches (102mm).

Exception: The top of the barrier shall be at least forty-eight (48) inches (1219mm) above ground level measured on the side of the barrier which faces away from the swimming pool provided the swimming pool is equipped with a rigid safety cover complying with ASTM F 1346.

2. through 10. Same as stated in International Residential Code.

SECTION 2. The repeal of Article II of Chapter 6 of the Code of Ordinances, City of Columbia, Missouri, relating to the 2012 Edition of the International Residential Code for One- and Two-Family Dwellings shall not affect any offense or act committed or done or any penalty or forfeiture incurred before the effective date of this ordinance.

SECTION 3. This ordinance shall be in full force and effect from and after \_\_\_\_\_

PASSED this \_\_\_\_ day of \_\_\_\_\_, 2013.